

USER MANUAL

AS THE ORIGINAL OPERATING MANUAL

DIN EN 15194 / DIN EN 82079-1

E-BIKE (PEDELEC/EPAC)



BOSCH

Sales:

Hermann Hartje KG

Tel: +49 (0)4251 811 500

info@hartje.de

www.hartje.de

Qio



1 E-bike components

The BOSCH drives consist of the components shown here. Depending on the model, the drives differ in terms of equipment, technical coordination and operation.

- Familiarise yourself with operation and functions, as well as the care and maintenance notes.

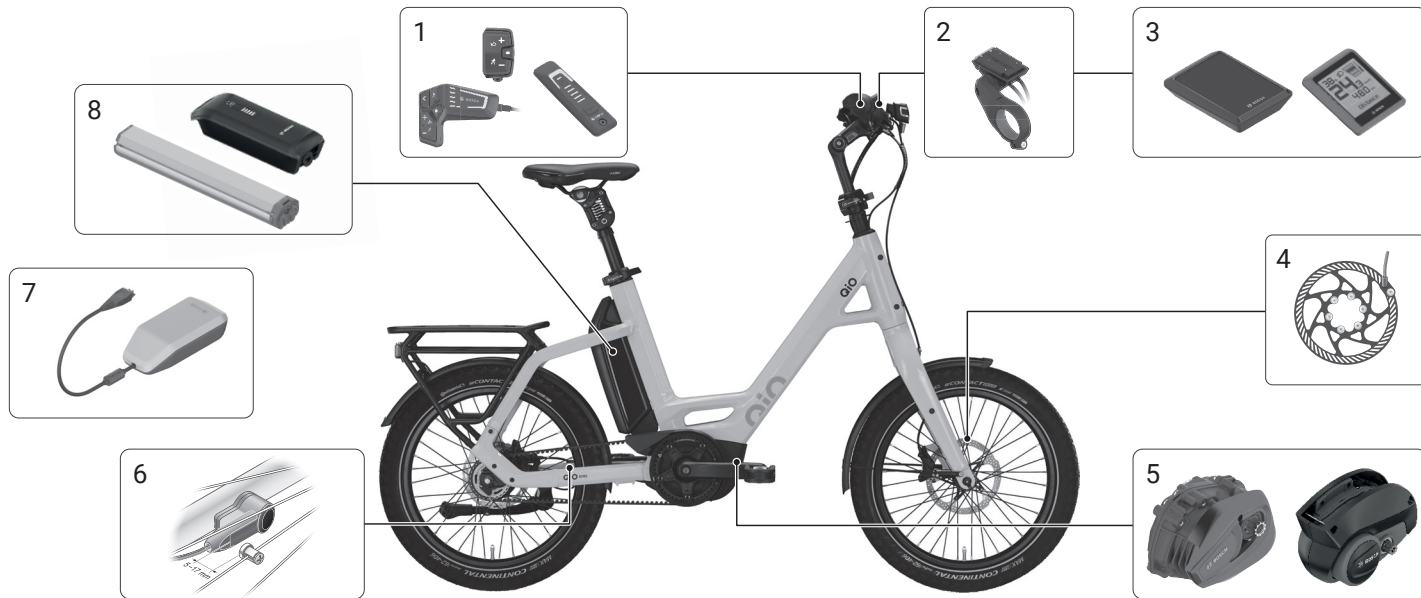

1 Control unit

2 Control computer holder

3 Control computer

4 ABS

5 Drive unit

6 Speed sensor

7 Charger

8 Battery

| | | | | | |
|-------|---|----|-------|--|----|
| 1 | E-bike components | 3 | 6 | Notes on the e-bike | 16 |
| 2 | In the case of an emergency | 7 | 6.1 | Differences between a conventional bicycle and an e-bike | 16 |
| 2.1 | General protective measures | 7 | 6.2 | Functionality | 16 |
| 2.2 | In the event of excessive heat | 7 | 6.3 | Range | 17 |
| 2.3 | In case of deformation, odour or leaking liquid | 7 | 6.4 | Cycling with a discharged battery | 17 |
| 2.4 | If the battery catches fire | 7 | 6.5 | Driving with ABS | 18 |
| 3 | Tuning or manipulation | 8 | 6.5.1 | Privacy statement | 18 |
| 4 | Safety | 9 | 6.5.2 | Basic information | 18 |
| 4.1 | Reading the user manual | 9 | 6.5.3 | Operation | 19 |
| 4.2 | Categorisation of warning notes | 9 | 6.6 | Drive overheat protection | 19 |
| 4.3 | Use | 10 | 7 | General notes on the battery | 20 |
| 4.4 | Battery | 10 | 7.1 | Charging times | 20 |
| 4.5 | Charger | 12 | 7.2 | Storing the battery | 20 |
| 4.6 | Button batteries | 12 | 7.3 | Transporting or shipping the battery | 21 |
| 4.7 | Residual risks | 13 | 7.4 | Temperature monitoring | 21 |
| 4.7.1 | Risk of injury | 13 | 7.5 | Electronic cell protection (ECP) | 21 |
| 4.7.2 | Fire hazard | 13 | 8 | Notes on use | 22 |
| 4.7.3 | Risk of damage | 13 | 8.1 | Information regarding road traffic | 22 |
| 5 | Basic information | 14 | 8.2 | Areas of application of the battery and charger | 22 |
| 5.1 | Symbols on the products | 14 | 8.3 | Insurance | 22 |
| 5.2 | Symbols in this manual | 15 | 8.4 | Lights | 22 |
| 5.3 | Terms | 15 | 8.5 | Permissible total weight | 22 |
| 5.4 | Written labels | 15 | 8.6 | Exclusion of wearable parts | 22 |
| 5.5 | Units | 15 | 8.7 | Disclaimer | 22 |

| | | | | |
|-----------|---|-----------|---|-----------|
| 9 | Transport | 23 | 11.3 Kiox 300 control computer holder | 32 |
| 9.1 | By car | 23 | 11.3.1 Mounting positions | 33 |
| 9.2 | Using other forms of transportation | 23 | 11.3.2 Installation of the control computer holder | 33 |
| 9.3 | Shipping | 23 | 11.3.3 Mounting on the handlebar | 34 |
| 10 | Start-up | 24 | 11.4 Control units | 35 |
| 10.1 | Before each ride | 24 | 11.4.1 LED Remote | 35 |
| 10.2 | Your first ride | 24 | 11.4.2 Mini Remote | 35 |
| 10.3 | Inspection instructions | 25 | 11.4.3 System Controller | 36 |
| 10.4 | Preparations | 25 | 11.4.4 Proper use | 36 |
| 10.4.1 | Battery | 25 | 11.4.5 Requirements | 36 |
| 10.4.2 | Charger | 25 | 11.4.6 Power supply of the control unit | 37 |
| 11 | Operation | 26 | 11.4.7 Switching the e-bike system on/off | 37 |
| 11.1 | Battery | 26 | 11.4.8 Charge indicator | 38 |
| 11.1.1 | Installation | 27 | 11.4.9 Setting the assistance level | 38 |
| 11.1.2 | Checking the battery before first use | 27 | 11.4.10 Interaction of the e-bike system with the shifting system | 39 |
| 11.1.3 | Charging the battery | 27 | 11.4.11 Switching the bicycle lights on/off | 39 |
| 11.1.4 | Charge indicator | 27 | 11.4.12 Shutting the walk assistance on/off | 39 |
| 11.1.5 | Removing and inserting the rechargeable battery | 28 | 11.4.13 ABS – Anti-lock braking system (optional) | 40 |
| 11.1.6 | Switching the battery on/off | 29 | 11.4.14 Establish a smartphone connection | 40 |
| 11.1.7 | Tips for the optimum handling of the battery | 30 | 11.4.15 Activity tracking | 40 |
| 11.1.8 | Recharge the battery before and during storage | 30 | 11.4.16 Lock function | 40 |
| 11.2 | Charger | 30 | 11.4.17 Software updates | 40 |
| 11.2.1 | Connecting the charger to the power supply | 31 | 11.5 Kiox 300 control computer | 41 |
| 11.2.2 | Charging the removed battery (PowerTube) | 31 | 11.5.1 Proper use | 41 |
| 11.2.3 | Charging the battery on the e-bike | 31 | 11.5.2 Inserting and removing the control computer | 41 |
| 11.2.4 | Charging process | 32 | 11.5.3 Inserting the securing plate | 42 |
| | | | 11.5.4 Operation | 42 |
| | | | 11.5.5 Start screen | 43 |
| | | | 11.5.6 Status screen | 43 |

| | | | |
|--|-----------|---|-----------|
| 11.6 Intuvia 100 control computer | 44 | 14 Error messages | 54 |
| 11.6.1 Proper use | 45 | 14.1 LED Remote control unit | 54 |
| 11.6.2 Inserting and removing the control computer | 45 | 14.1.1 Fewer critical errors | 54 |
| 11.6.3 Inserting the locking screw | 45 | 14.1.2 Critical errors | 54 |
| 11.6.4 Changing the batteries | 46 | 14.2 Battery | 55 |
| 11.6.5 Operation | 46 | 14.3 Charger | 55 |
| 11.6.6 Display indicator | 47 | 15 Technical data | 56 |
| 11.6.7 Speed and distance indicators | 47 | 15.1 Control computer | 56 |
| 11.6.8 Displaying and adjusting the basic settings | 48 | 15.2 Control computer holder | 56 |
| 11.7 Drive unit | 49 | 15.3 Control unit | 56 |
| 11.8 Speed sensor | 50 | 15.4 Bicycle lighting | 58 |
| 11.8.1 Speed sensor (slim) | 50 | 15.5 Bosch eBike ABS | 58 |
| 11.8.2 Rim magnet | 51 | 15.6 Drive unit | 58 |
| 12 Care | 52 | 15.7 Lithium ion rechargeable battery | 59 |
| 12.1 Notes on the battery lock key | 52 | 15.8 Charger | 59 |
| 13 Disposal | 53 | 16 Declaration of conformity | 60 |
| 13.1 Disposing of the e-bike and charger | 53 | 17 Legal notice | 61 |
| 13.2 Disposing of rechargeable batteries and batteries | 53 | | |
| 13.3 Disposing of the packaging | 53 | | |

2 In the case of an emergency

You can find notes on handling the battery in this user manual. Despite compliance with all safety measures, the battery poses a risk e.g. if it catches fire.

- In an emergency, behave in such a way that you do not at any time endanger yourself or other persons.
- In an emergency, follow the instructions on this page.
- Immediately read these instructions so that you can concentrate and respond in a calculated manner in the event of an emergency.
- We recommend keeping a suitable fire extinguisher on hand at all times.

2.1 General protective measures

If you identify defects or damage to the battery:

- Do not use the battery.
- Wear protective gloves when you touch the battery.
- Do not inhale any gases or vapours that are emitted.
- Avoid contact between your skin and any liquid that has leaked.

2.2 In the event of excessive heat

If you notice that excessive heat is being generated by the battery:

- Have the battery checked by your specialist dealer immediately. Inform your specialist dealer about the charge level before transport.
- For short-term temporary storage, select an outdoor location and, if possible, place the battery in a fire-proof container or on the soil.
- If you store the battery outdoors, clearly secure the area with ample space around the storage location and protect the battery from unauthorised access.

2.3 In case of deformation, odour or leaking liquid

If you identify any deformation, odour or liquid leaked on the battery:

- Place the battery in a fire and acid-proof container, e.g. made of rock or clay, and cover the battery with sand.
- Have your specialist dealer dispose of the battery immediately.
- For short-term temporary storage, choose an outdoor location.
- If you store the battery outdoors, clearly secure the area with ample space around the storage location and protect the battery from unauthorised access.

2.4 If the battery catches fire

If the battery catches fire, carcinogenic gases may be produced. Protect your respiratory system and avoid inhaling gases and smoke emitted during the fire.

- Call the fire brigade immediately.
- If there is no danger to you and you are physically able, use a suitable fire extinguisher to put out the fire.
- If there is no danger to you and you are physically able, cool the battery by placing it in fireproof container filled with water. The water must completely surround the battery.
- If there is no danger to you and you are physically able, cover the battery completely with sand.

3 Tuning or manipulation

WARNING

Risk of accident and injury!

Tuning or manipulating the speed settings of your e-bike may have a negative impact on your bicycle's braking or riding performance and may lead to accidents and injury.

- Do not make any structural modifications to the e-bike.

WARNING

Risk of accident and injury!

Tampering with the anti-lock braking system (ABS) can lead to brake failure.

- Do not make any structural modifications to the anti-lock braking system.

CAUTION

Risk of injury!

The e-bike may respond in a manner other than that which you expect if the e-bike system has been manipulated.

- Do not make any structural changes to the e-bike system.

NOTICE

Risk of damage!

You can cause irreparable damage to your e-bike by tuning it.

- Do not make any structural changes to the e-bike system.

- You can cause irreparable damage to your e-bike by tuning it.
- The frame, wheels and brakes are not designed for higher speeds.
- Any modification of the e-wheel system or the anti-lock braking system leads to the exclusion of the warranty or other claims.
- Tuning your e-bike has legal consequences.
- Operating an e-bike at speeds of over 25 km/h require a driving licence and an insurance policy as well as a registration plate.
- Riders of e-bikes at a speed above 25 km/h are subject to compulsory helmet use.
- Any modification of the e-bike system will result in the loss of your driving licence.
- Any modification of the e-bike system will result in the loss of insurance cover (personal liability).
- In the event of a repeat offence, an entry may be made in the police clearance certificate (criminal record).
- Any modification of the e-bike system will result in the loss of the Declaration of Conformity (CE).
- Any modification of the e-bike system precludes participation in road traffic.
- Any change to the anti-lock braking system can lead to brake failure.

4 Safety

4.1 Reading the user manual



Read all warnings and notes in this user manual with care before you operate the e-bike for the first time.

This user manual consists of supplementary instructions and applies in addition to the user manual of your e-bike. The complete scope of the original operating manual for your e-bike includes the bicycle user manual, this user manual and, if applicable, other included user manuals for the components installed on your e-bike.

Keep all user manuals so that they are handy and available at all times. Include the user manual when passing the e-bike on to third parties.

4.2 Categorisation of warning notes

The warning notes are intended to draw your attention to potential hazards. Your complete attention is required when reading the warning notes; the statements must be understood completely. Failure to follow a warning note may result in injury to yourself or other persons. The warning notes alone cannot prevent dangers.

- Follow all warning notes to avoid a risk when using the e-bike.

There are warning notes in the following categories:

DANGER

This key word designates a hazard with a moderate degree of risk which may lead to death or severe injury if unheeded.

WARNING

This key word designates a hazard with a moderate degree of risk which may lead to death or severe injury if unheeded.

CAUTION

This key word designates hazard with a low degree of risk, which may result in minor or moderate injury if unheeded.

NOTICE

This key word warns of possible damage to property.

4.3 Use

WARNING

Risks for children and persons with impaired physical, sensory or mental capacities or lack of experience and knowledge, e.g. children or persons with impaired mental and physical capacities!

The e-bike, battery and the charger may only be used by persons, who are able to act without restriction with respect to their mental and physical abilities. There is a high risk of injury for persons with restricted mental and physical capacities!

- Only allow the e-bike, battery and the charger to be used by persons briefed on safe and proper use and who understand the risks arising in connection with it.
- Do not let children play or ride the e-bike.

WARNING

Risk of accident and injury!

There is an increased risk of accident and injury if the e-bike is used in an improper manner or with disregard for regulations.

- Do not repair the e-bike yourself.
- Have repairs performed by your specialist dealer.

NOTICE

Risk of damage!

High or low temperatures could restrict the functioning of the e-bike or damage it.

- Take note of the temperature limits.
- Do not park the e-bike near heat sources.

4.4 Battery

WARNING

Risk of fire and explosion!

Batteries that have caught fire are very difficult to extinguish; the cells affected must burn down in a controlled manner. Responding properly may prevent severe damages.

- Read the section "2 In the case of an emergency" on page 7 so that you are prepared.

WARNING

Risk of fire and explosion!

Internal damage to the battery may cause the battery to overheat, emit gases or leak liquids even a significant amount of time after the damage has occurred.

- Have your specialist dealer inspect the battery after falls or severe impacts.
- Do not open, dismantle, drill through or deform the battery.

WARNING

Risk of fire and explosion!

Heat (e.g. strong sunlight), fire and other heat sources can damage the battery.

- Keep the battery away from fire and other heat sources; protect it against exposure to intense sunlight.
- Never leave the e-bike with the battery inserted in the blazing sun or expose it to strong heat.

CAUTION

Danger to health and the environment!

Lithium could leak if the battery is damaged. Lithium causes severe burns to the skin.

- Do not touch the damaged batteries with your bare hands.

NOTICE

Risk of damage!

Improperly charging the battery can damage the battery and the drive.

- Do not charge the battery if you suspect that it is damaged.
- Before charging the battery for the first time, make sure you read section "11.1.3 Charging the battery" on page 27.
- Only use the original charger to charge the battery and charge it only under supervision.
- While charging the rechargeable battery, always place it on non-flammable materials (e.g. stone, glass, ceramics).
- If you are not absolutely sure how to handle lithium ion batteries, have a qualified specialist explain how to do so.

NOTICE

Risk of damage!

Incorrect use of the battery could cause damage to the battery, the drive or surrounding objects, e.g. due to overheating.

- Only use the battery included in the product contents for the original drive.
- Only use original batteries approved for use with the original drive.
- Keep the battery away from fire and other heat sources; protect it against exposure to intense sunlight.
- Protect the dismantled battery against moisture.
- Never clean or spray the battery with liquids.
- Do not use the battery if you notice any unusual warmth, odour or discolouration and/or if the battery exhibits obvious damages.

4.5 Charger

DANGER

Risk to life!

Incorrect handling of electrical current and corresponding components poses a risk to life due to electric shock.

- Check the charger, mains cord and mains plug for damage before each use.
- If you identify or suspect damages, do not use the charger.
- Only use the charger indoors.
- Only connect the charger to a properly installed power supply, 220 to 240 V ~ (50 Hz) in Europe, (See "15 Technical data" on page 56).
- Set up the charger so that it is not able to become moist or wet, e.g. due to splashing water.
- Never clean or spray the charger with liquids.
- While charging, always place the charger on non-flammable materials (e.g. stone, glass, ceramics).
- Do not open, dismantle, drill through or deform the charger.
- Have the charger repaired only by qualified professionals with original spare parts.
- Only use the charger to charge the original battery or equivalent replacement batteries.
- Always pull the mains plug out of the socket after use.
- Read the additional safety notes on the housing of the charger.
- If the charger's power cord becomes damaged, it must be replaced with a special power cord available from the manufacturer or its after-sales service.

4.6 Button batteries

DANGER

Risk to life!

Button batteries should never be swallowed or inserted into other orifices of the body. If swallowed, button batteries can cause serious internal burning and death in just two hours.

- If you suspect that a button battery has been swallowed or inserted into another orifice of the body, call a doctor immediately.
- Keep button batteries out of reach of children.

WARNING

Risk of fire and explosion!

Damaged button cells can leak, explode, burn and cause injury to persons. If exposed to water, leaking lithium can produce hydrogen and cause a fire, an explosion or injury to persons.

- Do not open, dismantle, drill through or deform the button battery.
- Do not expose a damaged button battery to water.
- Do not try to recharge the button battery.
- Do not short-circuit the button battery.
- Remove and dispose of discharged button batteries properly.

WARNING

Risk of fire and explosion!

Heat (e.g. strong sunlight), fire and other heat sources can damage the button battery.

- Keep the button battery away from fire and other heat sources and protect it against exposure to intense sunlight.

NOTICE

Risk of damage!

Incorrect use of the button battery can damage the button battery and product.

- When replacing the button battery, make sure that it is replaced properly.
- Only use the button batteries listed in this user manual.
- Only use button batteries approved by the manufacturer.
- Do not use any other button batteries or another power supply.
- Keep button batteries away from fire and other heat sources and protect them from exposure to intense sunlight.
- Protect button batteries from moisture.
- Never clean or spray button batteries with liquids.
- Do not use the button battery if you notice any unusual warmth, odour or discolouration and/or if the button battery exhibits obvious damages.

4.7 Residual risks

Using the e-bike is associated with the following unforeseeable residual risks despite compliance with all safety notes.

4.7.1 Risk of injury

Gases, vapours and liquids could leak out of the battery due to internal, invisible damages and in the event of fire. Injuries to external and internal organs are possible, e.g. in the event of contact with skin or inhalation of the gases (*See "2 In the case of an emergency" on page 7*).

4.7.2 Fire hazard

Internal, invisible damage can cause the battery to catch fire and ignite objects in the surrounding area (*See "2 In the case of an emergency" on page 7*).

4.7.3 Risk of damage

If the battery catches fire, hydrofluoric acid leaks out with the smoke gas. Hydrofluoric acid is highly corrosive and permanently damages surfaces (*See "2 In the case of an emergency" on page 7*).

5 Basic information

5.1 Symbols on the products

The following symbols are located on the packaging, the battery or the charger:



Label for electrical devices that you must not dispose of with household waste. You are obligated by law to dispose of correspondingly labelled products at suitable recycling points for environmentally-friendly recycling.



Label for batteries and batteries that you must not dispose of with household or other garbage. You are obligated by law to dispose of correspondingly labelled products at suitable recycling points for environmentally-friendly recycling.



Label for rechargeable lithium ion battery that you must not dispose of with household or other garbage. You are obligated by law to dispose of correspondingly labelled products at suitable recycling points for environmentally-friendly recycling.



Label for environmentally-harmful hazardous substances. Exercise special caution when handling products labelled as such. Observe disposal guidelines!



Label for waste materials intended for recycling. Sort the packaging before you dispose of it. Dispose of cardboard and carton as waste paper and foils via the recyclable material collection service.



Symbol for products corresponding to the requirements of the European General Product Safety Directive.



Labelling for products that may only be used indoors.



Marking for products corresponding to protection class II: The product has double or reinforced insulation for protection against electric shock.



Symbol for direct current (DC).

5.2 Symbols in this manual

1. Instructions for steps to be performed in a particular order begin with a number.
 - Steps to be performed in no particular order begin with a dot.
 - Lists begin with a so-called dash.

 Supplementary notes regarding steps to be performed or use.

5.3 Terms

Terms with "nominal": Nominal output, nominal capacitance etc. are values stipulated according to the design. The actual values may differ from the nominal values depending on operating conditions.

E-bike: This manual generally uses the term "e-bike". This refers to Pedelecs.

Pedelec: "Pedelec" is a colloquial term used to describe electrically assisted bicycles. The normative term for pedelecs is EPAC (Electrical Power Assisted Cycles). Pedelecs have electric drive assistance up to a maximum speed of 25 km/h and are treated as bicycles from a legal perspective.

Capacitance: Capacitance in the unit ampere hours "Ah" when the battery is fully charged (See "5.5 Units" on page 15).

Charging cycle: Refers to fully charging a completely depleted battery.

Memory effect: Refers to the loss in the capacitance of batteries if they are not completely charged (does not apply to lithium ion rechargeable batteries).

Pedal drive: Assembly consisting of pedal, crank arm and chain wheel.

Temperature limits: Minimum and maximum temperature at which the corresponding component may be used. Temperature limits can be specified for a component itself and for the ambient temperature.

Pedalling frequency: Number of revolutions of the pedal drive in one minute expressed in the unit "rpm".

5.4 Written labels

Text references are indicated by *italics*.

5.5 Units

| Unit | Meaning | Unit for |
|------|--------------|--------------------------------|
| rpm | Per minute | Revolutions per minute |
| A | Amperes | Electric current (=W/V) |
| Ah | Ampere hour | Electric charge (=Wh/V) |
| g | Gram | Weight (= kg/1000) |
| Hz | Hertz | Frequency (Hz = oscillation/s) |
| kg | Kilogram | Weight (= g×1000) |
| Nm | Newton meter | Torque |
| V | Volt | Electric voltage (=W/A) |
| W | Watt | Electrical power (=V×A) |
| Wh | Watt hour | Electric capacitance (=V×Ah) |

6 Notes on the e-bike

E-bikes are available with a speed of up to 25 km/h or with a speed of over 25 km/h.

E-bikes with a speed of up to 25 km/h do not require a licence within the EU.

Stricter regulations apply to e-bikes which travel at speeds of over 25 km/h which will be indicated separately.

The term “e-bike” is used in this original operating manual for both categories.

6.1 Differences between a conventional bicycle and an e-bike

The additional components of the electric drive constitute the major differences between a conventional bike and an e-bike.

- The e-bike is significantly heavier and its weight distribution is different from conventional bicycles. This results in different handling.
- The drive has a significant effect on braking characteristics.
- E-bikes require greater braking forces. This may result in greater wear than with conventional bicycles.
- The electrical assistance will increase your average speed.
 - You should therefore cycle attentively. Keep in mind that other road users must get used to the increased speed of the e-bike.
- The bike's handling and braking, as well as handling of the battery and charger, require an appropriate level of knowledge.
 - Familiarise yourself with the features of your e-bike, even if you already have some experience with electrically assisted bicycles (See “10.2 Your first ride” on page 24).

6.2 Functionality

The drive only provides you with riding assistance when you pedal. The intensity of assistance is automatically adjusted depending on the selected riding mode, the pressure applied when pedalling, the load and the speed. The drive assists you up to a speed of 25 km/h.

The A-weighted emission sound pressure level at the driver's ears is less than 70 db(A).

6.3 Range

The drive is an assistive motor. The range is affected by your pedalling intensity.

- Set the assistance as low as possible.

The lower the pedalling frequency of the pedal drive, the higher the energy requirement for the drive.

- Use the gear shift as you would without assistance.
- For inclines, head wind or a heavy load, use the lower gears of the gear shift.

The drive requires a large amount of energy when starting.

- Always start in a low gear and apply as much pressure to the pedal as possible.
- Before travelling uphill, switch to a lower gear in time.
- Ride with foresight to avoid any unnecessary stops. The energy consumption will increase with high loads.
- Do not transport any unnecessary loads.

Lack of care and maintenance may reduce the range.

- Handle the e-bike with care and observe all notes regarding the battery in this user manual.
- Check the tyre pressure regularly.
- Comply with the maintenance intervals.

Temperatures below +10 °C may negatively affect the performance of the battery during operation. When you are not using your e-bike:

- At low outdoor temperatures, take the battery out of the holder and store it (See "7.2 Storing the battery" on page 20).
- Only put it back in the holder directly before cycling.

6.4 Cycling with a discharged battery

If the battery charge is completely used up during the ride, you can use your e-bike as you would a normal bike.

 If the battery charge has been used up, the drive will switch off. The lighting will be supplied with energy for another 2 hours.

6.5 Driving with ABS

CAUTION

Risk of accident and injury!

Failure of the ABS due to incorrectly selected spare parts.

- Seek advice from your specialist dealer about appropriate replacement parts.
- Only use original spare parts.

CAUTION

Risk of accident and injury!

Increased braking distance due to the ABS and an increased risk of falling during braking manoeuvres in bends.

- Drive with foresight.
- Adapt your driving style to the ambient conditions.

CAUTION

Risk of accident and injury!

Prolonged braking may cause the ABS to stop working.

- Briefly releasing the front brake puts the ABS back into operation.

6.5.1 Privacy statement

When the e-bike is connected to the Bosch DiagnosticTool, data on the use of the Bosch eBike ABS (including brake pressure, deceleration, etc.) is transmitted to Bosch eBike Systems (Robert Bosch GmbH) for product improvement purposes. You can find more information on the Bosch eBike website www.bosch-ebike.com.

6.5.2 Basic information

Depending on the model, your e-bike is equipped with an ABS (anti-lock braking system).

- Do not make any structural modifications to the anti-lock braking system (See "3 *Tuning or manipulation*" on page 8).

The ABS prevents the wheels from locking during braking. The road grip remains intact.

6.5.3 Operation

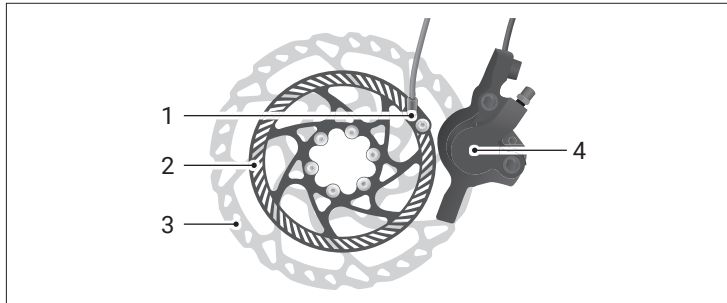

Fig.: 1 ABS components

- | | |
|----------------------|------------------|
| 1 Wheel speed sensor | 3 Brake disc |
| 2 Sensor disc | 4 Brake calliper |

The ABS is only available when the battery is charged and inserted.

If the battery charge is used up, the brake system remains functional and only the ABS control is not available.

The indicator light of the ABS should light up after switching on and should go out at approx. 5 km/h after you start riding.

If the indicator light does not go out after you start riding or if it lights up during the ride, there is a fault in the ABS.

The functionality of the brake system is retained, and the ABS control is no longer present.

When the brakes are applied, the ABS detects the rotation of the wheels through wheel speed sensors on the front and rear wheels.

If one of the wheels threatens to come to a standstill, the ABS limits the brake pressure on the front wheel and stabilises it.

The ABS function is terminated by one of the following events:

- The storage chamber in the ABS control unit is completely filled.
- The e-bike has come to a stop.
- The driver releases the brake.
- When switching on the system, check that the ABS indicator light illuminates in the display.
- Before each ride, check the function of the front and rear brakes.

6.6 Drive overheat protection

CAUTION

Risk of injury!

The drive and battery can become very hot if a fault is at hand. You could injure yourself in the event of contact with your skin.

- In this case, do not touch the drive and the battery.

The drive is automatically protected against damage caused by overheating. If the temperature of the drive is too high, the drive will automatically switch off.

- To avoid overheating the drive, set a low level of assistance when the outside temperature is high or the driving distance rises sharply.
- If the drive switches off when the battery is charged and at a speed of under 25 km/h, do not use the e-bike temporarily to allow the drive to cool off.
- If allowing the drive to cool off does not resolve the disturbance, have your specialist bike dealer inspect the e-bike.

7 General notes on the battery

NOTICE

Risk of damage!

Self-discharge of the battery for technical reasons may cause irreparable damages.



- Immediately recharge the battery if it is empty.

Your e-bike is equipped with a high-quality lithium-ion rechargeable battery (Li-ion battery). Li-ion batteries are safe if used properly.

Li-ion batteries have a relatively high energy density. Therefore, this battery must be handled with great care. For your safety, be absolutely sure to observe the following notes to ensure reliable operation and a long life-cycle:

Partial charging does not damage the battery as it does not have a memory effect.

Partial charging is evaluated according to the capacitance of the battery (a charge of 50% corresponds to a ½ charge cycle).

 Depending on the model, your battery uses one of the following On/Off symbols,  or .

- Observe the temperature limits for the battery (See "15.7 Lithium ion rechargeable battery" on page 59).
- Please note that outside temperatures under +10°C may reduce the power of the battery.
- Remember that the battery loses power as it ages.
- Keep in mind that you will get used to cycling with electrical assistance after a while. This may result in a perceived drop in the output of the battery.
- If there is a loss of power or the operating time is significantly reduced, contact your specialist dealer.
- Never perform any modifications on the battery.

 Further information on the battery (See "4.4 Battery" on page 10).

7.1 Charging times

If the battery is empty, a full charge cycle requires up to 6 hours.

The duration of the charge cycle depends on the following factors:

- Battery capacitance
- Charge level of the battery.
- Temperature of the battery and surroundings.

7.2 Storing the battery

If you do not use the battery for a prolonged period of time, please store it as follows:

- Charge the battery to approximately 30% to 60% of the capacitance.
- For storage, take the battery out of the holder and place it in a safe location.
- Store the battery so that there is no risk of it falling and so that it is out of reach of children and animals.
- If possible, store the battery at room temperature in a dry, well-ventilated space.
- Store the battery optimally at about +10°C to +15°C in a well-ventilated place, e.g. in the cellar.
- Protect the battery against moisture and water.
- Make sure that the upper and lower temperature limit is not exceeded or undershot during storage (See "15.7 Lithium ion rechargeable battery" on page 59).

For storage exceeding 3 months, please recharge the battery every quarter to half year depending on storage conditions.

- Then charge the battery again to approx. 30% to 60% of the capacitance.
- After the charging process, always disconnect the charger from the battery and pull the mains plug out of the socket.

7.3 Transporting or shipping the battery

Lithium ion batteries are subject to the requirements of dangerous goods legislation. The private user may transport undamaged batteries on the road without any further requirements.

- Please note that the special requirements for packaging and labelling, e.g. during air transport or shipping orders, apply for commercial transport.
- Contact the forwarding company or your specialist bicycle dealer directly for information regarding the transportation of the battery and suitable transport packaging.

To transport the e-bike, read the section "9 Transport" on page 23.

7.4 Temperature monitoring

CAUTION

Risk of injury!

Temperatures of over 40°C can cause injury to the skin.

- If you would like to end the charging process prematurely, let the battery cool off.

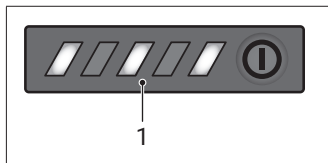

1 Overheat protection

Fig.: 2 Error displays

The battery is equipped with a temperature monitor. It can only be charged at temperatures between 0 °C and +40 °C. If the battery is not within the temperature range for charging, the three LEDs on the charge indicator will flash.

- Disconnect the battery from the charger and let it cool to the operating temperature.
 - Only connect the battery to the charger again once it has reached the permissible charging temperature.
1. Pull the mains plug out of the socket.
 2. Once the battery has cooled off, pull the charging plug out of the charging socket.
 3. Have your specialist dealer inspect the battery.
 - Inform your specialist dealer about the charge level before transport.

7.5 Electronic cell protection (ECP)

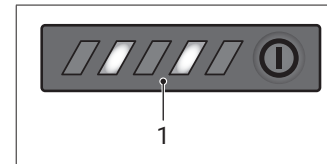

1 Electronic cell protection

Fig.: 3 Error displays

Electronic cell protection (ECP) protects the battery against deep discharge, overcharging and short-circuiting. If there is a risk, a protective circuit will automatically deactivate the battery. If a defect in the battery is detected, two LEDs on the charge indicator will flash.

- If the "ECP" error appears, have the battery inspected by your specialist dealer.

8 Notes on use

8.1 Information regarding road traffic

The assistance provided by e-bikes is effective up to a speed of 25 km/h. The technical configuration of your e-bike complies with European standard EN 15194 for electrically power-assisted bicycles and bicycle standard EN ISO 4210.

- Seek information regarding the relevant applicable road traffic regulations for your country or region, e.g. From your local Ministry for Transport.
- Ensure that you regularly obtain information regarding changes to the content of valid regulations.

8.2 Areas of application of the battery and charger

The drive unit, battery and charger are configured for use with one another and are approved only for use with your e-bike.

8.3 Insurance

- Check whether the conditions of your insurance policies (e.g. liability insurance, household contents insurance) provide sufficient cover for damage.
- In case of doubt, contact your insurance company.

8.4 Lights

Your e-bike is equipped with battery-powered lighting. The battery must always be inserted when using public roads so that the lighting is operational at all times.

Depending on the model, the rear light flashes briefly when the lights are switched on to inform following traffic that the lights have been switched on.

8.5 Permissible total weight

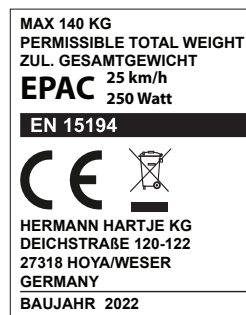

Fig.: 4 CE sticker (example)

The total admissible weight of your e-bike is specified on the CE sticker. The sticker is attached either to the underside of the down tube or to the inside of the seat tube.

8.6 Exclusion of wearable parts

In addition to the wearable parts listed in the user manual for the bicycle, the battery – with the exception of production defects – is not covered by the warranty.

8.7 Disclaimer

The manufacturer cannot be held liable for damage or breakdowns resulting from direct or indirect use of the e-bike.

9 Transport

WARNING

Risk of short-circuiting and fire!

The lithium ion battery is considered a dangerous good and may be damaged if exposed to shocks and impacts without such damages being externally apparent.

- When transporting your e-bike, remove the battery and store it separately.
- Transport the battery with special care.

9.1 By car

- Store the battery so as to prevent slipping and collision with other objects during the trip.
- Properly secure the load to protect the battery against compressive loads and avoid shocks.
- Store the battery so that it is unable to be heated up by exposure to the sun or other heat sources.

Due to the higher weight of e-bikes, the resulting forces that arise when braking and turning corners are greater than in the case of conventional bicycles.

- Check whether your bike rack is suitable for e-bikes.
- Ask your specialist dealer about suitable bike racks for your e-bike.

 The use of roof-mounted bicycle racks for e-bikes is prohibited.

9.2 Using other forms of transportation

When transporting e-bikes, special guidelines, which are constantly being expanded or updated, apply. These guidelines may differ from one another depending on the form of transportation.

- Contact the airline, train or ferry company in due time to get informed regarding valid provisions that apply for transporting e-bikes. Have the technical data handy for this purpose (See "15 Technical data" on page 56).

9.3 Shipping

If you are shipping your e-bike, ship the rechargeable battery separately and well packed in a suitable transport container.

10 Start-up

CAUTION

Risk of injury!

The e-bike may respond in a manner other than you expect if operated incorrectly.

- Read the section “11 Operation” on page 26 completely before switching on for the first time.

NOTICE

Risk of damage!

If the battery is not fully charged before the initial start-up, the nominal charge of the battery will decrease.

- Before the initial start-up, charge the battery until the charge indicator on the battery goes out.

10.1 Before each ride

Check your e-bike according to section “10.3 Inspection instructions” on page 25 in this user manual and in the user manual for your bicycle.

- Fully charge the battery before your first ride.

10.2 Your first ride

- Practice operating and using it in an open area away from public traffic.
 - Practice on level, solid ground with adequate grip.
1. Select the lowest support on the control unit. Start slow.
 2. Operate the brakes carefully and get used to the braking effect; on models with an ABS, get used to the ABS control.
 3. Once you are able to safely operate the brakes, familiarise yourself with the assistance function.
 4. Once you are able to ride safely, repeat the familiarisation phase and test the brake in other riding modes.
 5. Practice using the walk assistance function (See “11.4.12 Shutting the walk assistance on/off” on page 39).

10.3 Inspection instructions

- Check whether the battery lock is engaged.
- Check the battery for any damage (visual inspection).
- Check the drive for any damage (visual inspection).
- Check the cables and plug connections for damage and make sure they are securely fastened (visual check).
 - If you discover any missing or damaged parts, do not use the e-bike.
 - Have your specialist dealer repair the e-bike.
- Make sure that the front and rear brakes are working properly.

Note: Depending on the type of bicycle, your e-bike will be equipped with a frame battery, a rack battery or a battery integrated into the frame.

10.4 Preparations

1. Read the entire user manual before you use the e-bike.
2. Prepare the battery and the charger for the start-up of your e-bike.

10.4.1 Battery

Depending on the model, your e-bike is equipped with two batteries.

- To use the e-bike, one of the two batteries must be inserted and charged.
- If both batteries are inserted, they are discharged simultaneously.

10.4.2 Charger

A summary of important safety notes with the following content is located on the bottom of the chargers:

- Observe the user manual to ensure safe use. Risk of electrical shock.
- Only use in a dry environment.
- Only charge Bosch batteries with the corresponding Bosch charger. Other batteries may explode and cause injury.
- Do not replace the mains cord. This poses a risk of fire and explosion. Contact your dealer to replace the power cord. Only have the mains cable replaced with an original spare part.
- Read the information on the nameplate of the charger.
- If the information does not correspond to the voltage supply, do not use the charger. Before connecting the charger to the power supply.

11 Operation

11.1 Battery

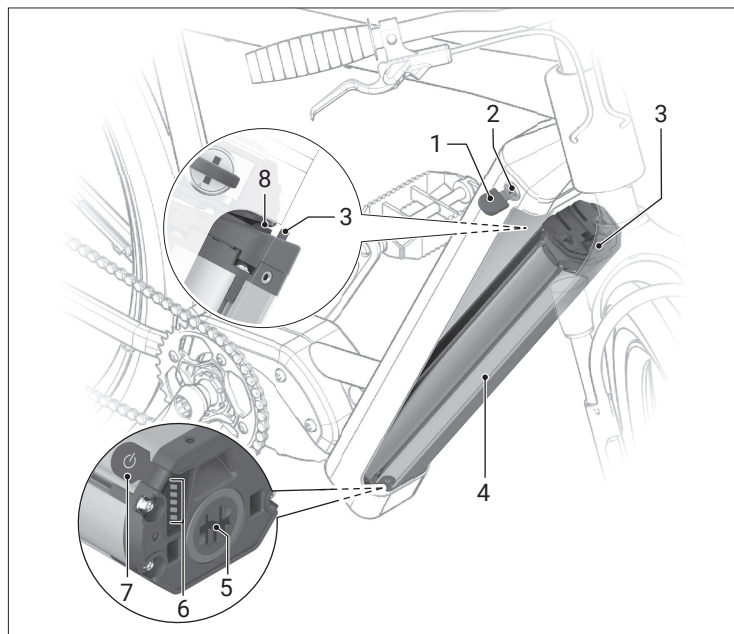

Fig.: 5 PowerTube battery overview

- | | |
|---------------------------------|--|
| 1 Battery lock key | 5 Socket for charging plug |
| 2 Battery lock | 6 Operating and charging status display |
| 3 Safety hook PowerTube battery | 7 On/Off button on the battery  |
| 4 PowerTube battery (pivot) | 8 Restraint system |

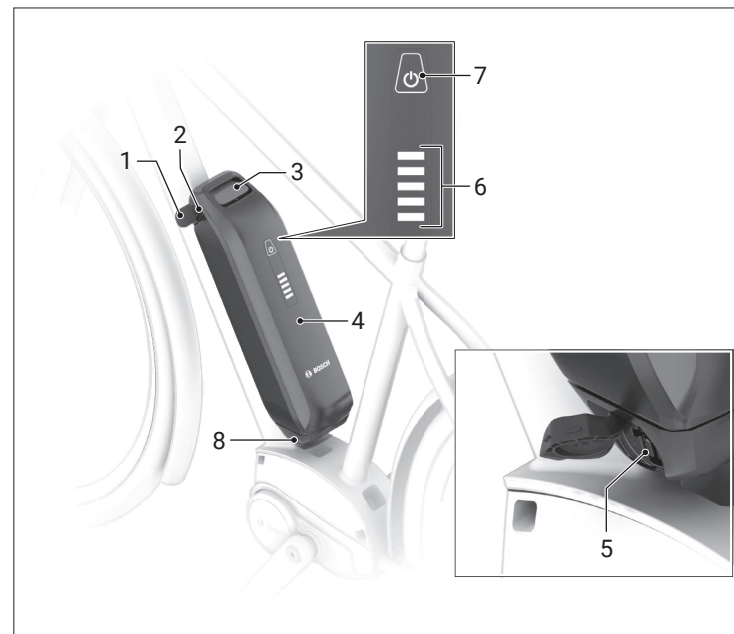



Fig.: 6 PowerTube battery overview

- | | |
|---|--|
| 1 Battery lock key | 5 Socket for charging plug |
| 2 Battery lock | 6 Operating and charging status display |
| 3 PowerPack rechargeable battery upper holder | 7 On/Off button on the battery  |
| 4 PowerPack rechargeable battery | 8 PowerPack rechargeable battery bottom holder |

11.1.1 Installation

- Only place the battery on clean surfaces.
- In particular, avoid soiling the charging socket and contacts, e.g. with sand or dirt.

11.1.2 Checking the battery before first use

- Check the battery before you charge it for the first time or use it with your e-bike.
 - To switch on, press the On/Off button on the battery .
- If no LED of the charge indicator lights up, the battery may be damaged.
If at least one, but not all LEDs on the charge indicator illuminate, fully charge the battery before using it for the first time.

 Do not charge or use a damaged battery. Consult an authorised specialist dealer.

11.1.3 Charging the battery

 A Bosch e-bike battery may only be charged with an original Bosch e-bike charger.

The battery is delivered partially charged. To ensure full performance of the battery, fully charge it with the charger before the first use.

- To charge the battery, also read and observe section “11.2 Charger” on page 30.

The battery can be charged at any charge level. Interrupting the charging process will not damage the battery.

The battery is equipped with a temperature monitor, which only permits charging within a temperature range between 0°C and 40°C.

If the battery is not within the temperature range for charging, the three LEDs on the charge indicator will flash.

- Disconnect the battery from the charger and let it cool down.
- Only connect the battery to the charger again once it has reached the permissible charging temperature.

11.1.4 Charge indicator

The five green LEDs of the charge indicator show the charge level of the battery when it is switched on.

Each LED corresponds to approx. 20 % of the capacitance. All five LEDs will illuminate once the battery is fully charged.

The charge level of the switched-on battery is also shown on the display of the control computer.

If the capacity of the battery is below 5 %, all LEDs of the charge indicator on the battery go out, but there is still a display function of the control computer.

- After charging, disconnect the battery from the charger and the charger from the mains.

11.1.5 Removing and inserting the rechargeable battery

11.1.5.1 Removing the PowerTube battery (pivot)

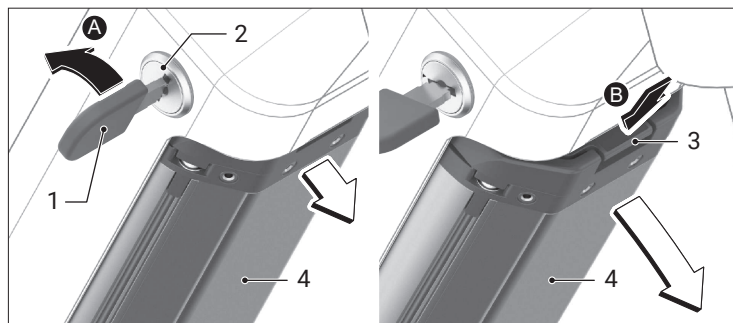

Fig.: 7 Removing the PowerTube battery (pivot)

- | | |
|--------------------|---------------------|
| 1 Battery lock key | 3 Restraint system |
| 2 Battery lock | 4 PowerTube battery |

Always switch off the battery and the e-bike system when inserting the battery into or removing it from the holder.

1. To remove the PowerTube battery, open the battery lock with the key. The battery is unlocked and falls into the restraint.
2. Press on the restraint from above. The battery is completely unlocked and falls into your hand.
3. Pull the battery out of the frame.

i Due to design differences, inserting and removing the battery may have to be done in a different way. To do so, contact an authorised dealer.

11.1.5.2 Inserting a PowerTube battery (pivot)

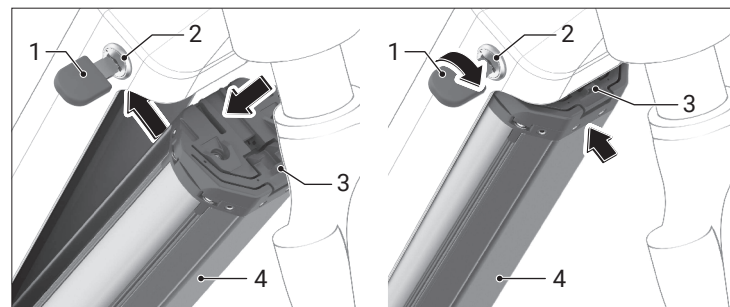

Fig.: 8 Inserting a PowerTube battery (pivot)

- | | |
|--------------------|---------------------|
| 1 Battery lock key | 3 Restraint system |
| 2 Battery lock | 4 PowerTube battery |

In order for the battery to be inserted, the key must be in the battery lock and the battery lock must be unlocked.

1. To insert the battery, place it with the contacts in the lower holder of the frame.
2. Tip the battery upwards until it is held by the restraint.
3. Hold the lock open with the key and push the battery upwards until you hear it clearly click into place.
4. Check in all directions that the battery is firmly seated.
5. Always lock the battery to the battery lock, otherwise the battery lock may open and the battery may fall out of the holder.
6. After locking, always pull the key out of the battery lock. This prevents the key from falling out or the battery from being removed by unauthorised third parties when the e-bike is parked.

11.1.5.3 Removing and inserting the PowerPack battery

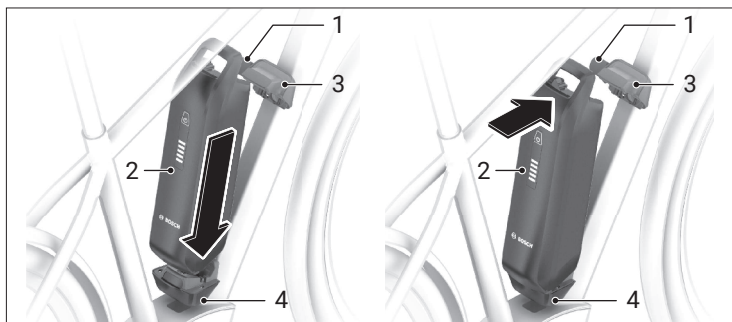

Fig.: 9 Removing and inserting the PowerPack battery

- | | |
|----------------------------------|--|
| 1 Battery lock key | 3 PowerPack rechargeable battery upper holder |
| 2 PowerPack rechargeable battery | 4 PowerPack rechargeable battery bottom holder |

Always switch off the battery and the e-bike system when inserting the battery into or removing it from the holder.

Do not ride with the key inserted. Make sure that the key is no longer inserted when you park the e-bike.

Removing the PowerPack battery

1. Open the battery lock with the key. The battery is unlocked.
2. Tilt the battery out of the upper holder and pull it out of the upper holder.

Replacing the PowerPack battery

When inserting the battery, the key should not be in the battery lock.

1. Place the battery with the contacts on the bottom holder.
2. Tilt the battery until it visibly and audibly reaches the stop point in the upper holder.

i Due to design differences, inserting and removing the battery may have to be done in a different way. To do so, contact an authorised dealer.

11.1.6 Switching the battery on/off

⚠ WARNING

Risk of injury and fire hazard!

Using other battery packs may result in injury and a risk of fire. Bosch accepts no liability or warranty for the use of other batteries.

- Only use original Bosch batteries that have been approved by the manufacturer for your e-bike.

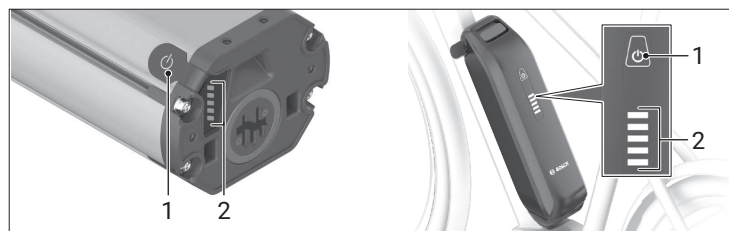

Fig.: 10 Switching the battery on/off

- | | |
|--------------------------------|--------------------|
| 1 On/Off button on the battery | 2 Charge indicator |
|--------------------------------|--------------------|

Switching on the battery is one of the ways to switch on the e-bike system.

Before switching on the battery or the e-bike system, make sure that the lock is locked.

1. To switch on the battery, press the On/Off button on the battery. Do not use sharp or pointed objects to press the button. The charge indicator LEDs light up to indicate the charge level.

i If the capacitance of the battery is under 5%, none of the LEDs for the charge indicator will illuminate on the battery. Only an indicator on the control computer/control unit shows whether the e-bike system has been switched on.

2. To switch off the battery, press the On/Off button on the battery again .

The LEDs of the charge indicator go out.

This also switches off the e-wheel system.

If no power is called up from the e-bike drive for about 10 minutes (e.g. because the e-bike is stationary) and no button is pressed on the control computer or control unit of the e-bike, the e-bike system switches off automatically.

Electronic cell protection (ECP) protects the battery against deep discharge, overcharging, overheating and short-circuiting. If there is a risk, a protective circuit will automatically deactivate the battery.

If a defect in the battery is detected, two LEDs on the charge indicator will flash. Consult an authorised specialist dealer in this case.

11.1.7 Tips for the optimum handling of the battery

The life of the battery can be extended if it is well cared for and, above all, stored at the right temperatures.

However, as the battery ages, its capacity will decrease, even with good care.

A significantly reduced operating time after charging indicates that the battery is depleted. You can replace the battery with a suitable original Bosch battery.

11.1.8 Recharge the battery before and during storage

If the battery will not be used for a long time (> 3 months), store it at about 30% to 60% charge (2 to 3 LEDs of the charge indicator light up).

Check the charge level after 6 months. If only one LED of the charge indicator is still lit, then charge the battery again to about 30% to 60%.

 If the battery is stored for a long time in an empty state, it can be damaged despite the low self-discharge and the storage capacity can be greatly reduced. It is not recommended to leave the battery permanently connected to the charger.

11.2 Charger

WARNING

Fire hazard!

There is a risk of fire if the charger heats up during charging.

- Only charge the batteries on the bike when they are dry and in a fire-safe place.
- Read and note also "11.1 Battery" on page 26.

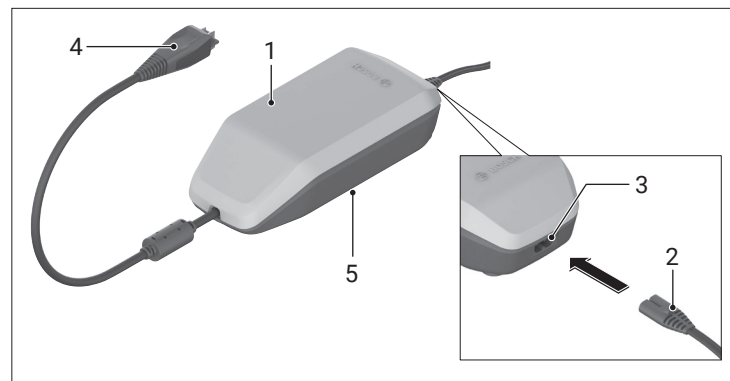

Fig.: 11 Charger overview

- | | |
|---------------|-----------------------------------|
| 1 Charger | 4 Charging plug |
| 2 Device plug | 5 Safety instructions for charger |
| 3 Device jack | |

11.2.1 Connecting the charger to the power supply

1. Observe the mains voltage.
The voltage of the power source must match the specifications on the charger's rating plate. Chargers labelled with 230 V can also be operated at 220 V.
2. Insert the device plug of the mains cord in the device jack on the charger.
3. Connect the mains cable (country-specific) to the mains.

11.2.2 Charging the removed battery (PowerTube)

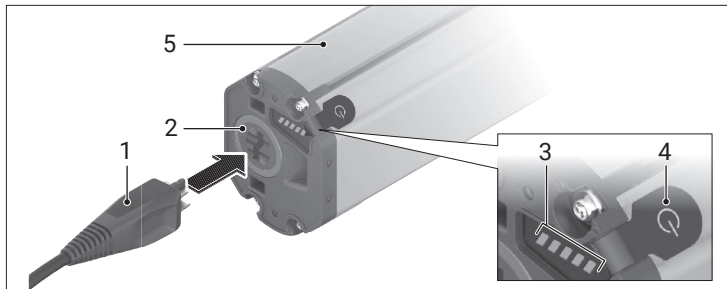

Fig.: 12 Charging the removed battery (PowerTube)

- | | |
|---|---|
| 1 Charging plug | 4 On/Off button for battery  |
| 2 Socket for charging plug | 5 PowerTube battery |
| 3 Operating and charging status display | |

1. Switch off the battery and remove it from the holder on the e-bike (See "11.1 Battery" on page 26).
2. Only place the battery on clean surfaces.
 - In particular, avoid soiling the charging socket and contacts, e.g. with sand or dirt.
3. Insert the charger plug of the charger into the socket on the battery.

11.2.3 Charging the battery on the e-bike

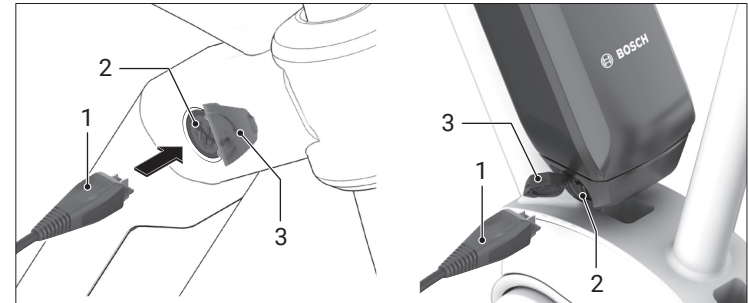

Fig.: 13 Charging the battery on the e-bike

- | | |
|----------------------------|-------------------------|
| 1 Charging plug | 3 Charging socket cover |
| 2 Socket for charging plug | |

1. Switch off the battery.
2. Clean the cover of the charging socket.
 - In particular, avoid soiling the charging socket and contacts, e.g. with sand or dirt.
3. Lift off the cover of the charging socket and insert the charging plug in the charging socket.

11.2.4 Charging process

i Charging is only possible when the temperature of the battery is within the permissible charging temperature range. During the charging process, the drive unit is deactivated.

The battery can be charged with or without the control computer. Without a control computer, the charging process can be observed on the charge indicator.

When the control computer is connected, a corresponding message is shown on the display. The charge level is indicated by the operating display and charge indicator on the battery and by the bars on the control computer.

During the charging process, the LEDs of the operating display and charge indicator on the battery light up. Every continuously illuminated LED represents approx. 20% of the capacitance. The flashing LED indicates the charge of the next 20%.

If the battery is fully charged, the LEDs will go out immediately and the control computer will switch off. The charging process will end. By pressing the On/Off button on the battery , the charging status can be displayed for 5 seconds.

1. Connect the charger to the battery or the charging socket on the e-bike and to the mains.
The charging process begins as soon as the charger is connected to the battery or the charging socket on the e-bike and the mains.
2. Disconnect the charger from the mains and the battery from the charger.
The battery will automatically switch off when the battery is disconnected from the charger.
3. After the charging process is complete, carefully put the cover on the charging socket to prevent dirt and water from penetrating it.

i If the charger is not disconnected from the battery after charging, the charger switches on again after a few hours, checks the charge level of the battery and starts charging again if necessary.

11.3 Kiox 300 control computer holder

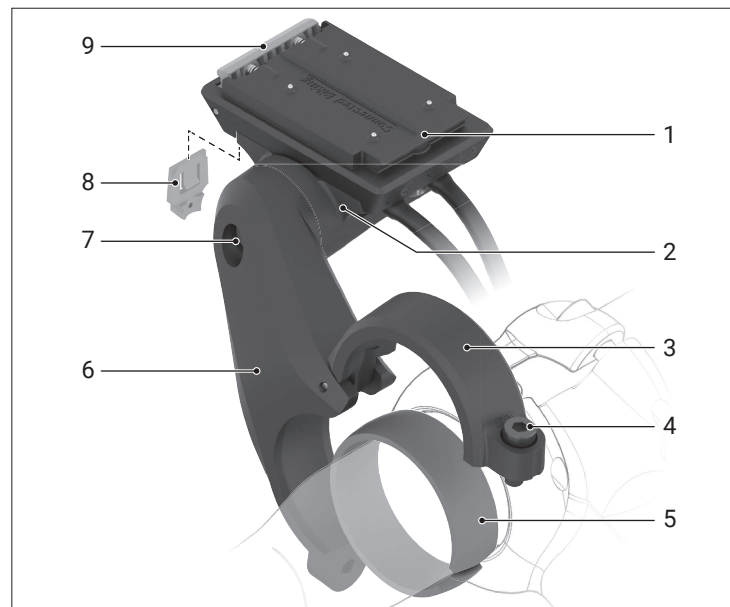

Fig.: 14 Kiox 300 control computer holder overview

- | | |
|---------------------------|-----------------------------|
| 1 Control computer holder | 6 1-arm holder |
| 2 Adapter tray | 7 Screw for tilt adjustment |
| 3 Clamp for bracket | 8 Fuse plate |
| 4 Clamp screw | 9 Snap-in hook |
| 5 Spherical spacer rubber | |

11.3.1 Mounting positions

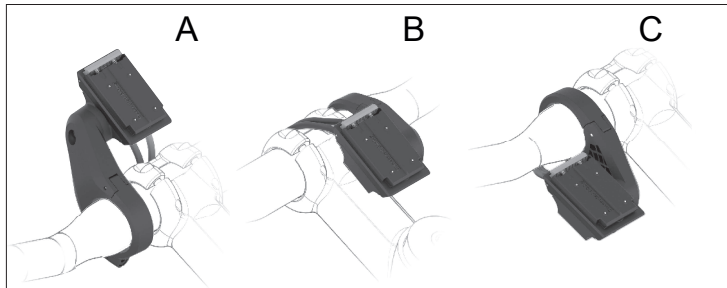



Fig.: 15 Mounting positions of the control computer holder

- A In front of the handlebar
 B Above the stem
 C In the handlebar triangle

The 1-arm holder can be mounted in three different positions on the handlebar.

To ensure uncomplicated cable routing, the appropriate control computer holder must be used for each of the different positions:

- A: Control computer holder BDS3210 (electrical connections at the rear)
 B: Control computer holder BDS3250 (electrical connections at the front)
 C: Control computer holder BDS3250 (electrical connections at the front)

 If you want to change the mounting position and you have the correct control computer holder, you must first dismount the 1-arm bracket and then remount it.

 Note that there are two different handlebar diameters (31.8 mm and 35 mm). Your specialist dealer will help you choose the right components.

11.3.2 Installation of the control computer holder

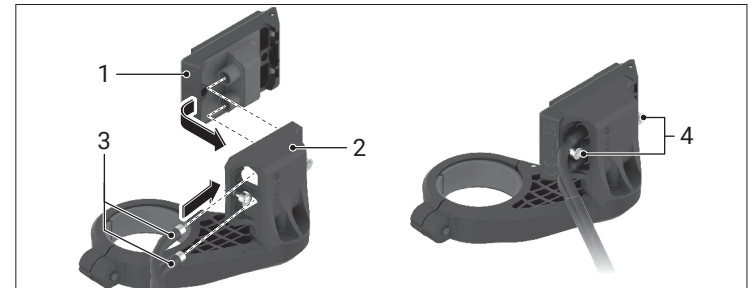



Fig.: 16 Installation of the control computer holder

- 1 Control computer holder
 2 Adapter tray
 3 Connection cable
 4 Fixing screws

1. Insert the control computer holder into the adapter tray.
Pay attention to the desired installation position.
2. Screw the control computer holder in place from below using the fastening screws.
When doing so, pay attention to the torque indicated on the adapter shell.
3. Connect the connection cables coming from the drive unit and control unit to the control computer.

 Make sure that the markings on the plug and connection cable match.

11.3.3 Mounting on the handlebar

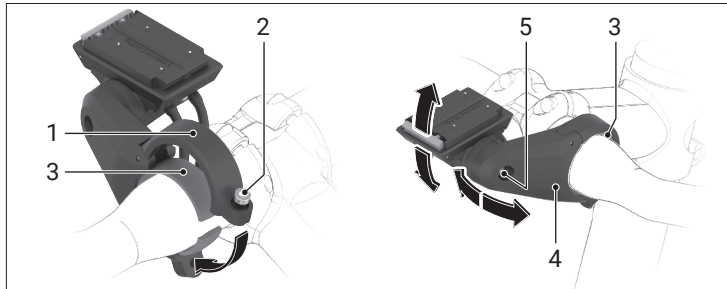

Fig.: 17 Mounting on the handlebar

- 1 Clamp for bracket
- 2 Clamp screw
- 3 Spherical spacer rubber

- 4 1-arm holder
- 5 Screw for tilt adjustment

i The control computer holder may only be attached in the cylindrical area of the handlebar and not in the conical area. In order to be able to clamp a control computer centrally, the handlebar must have a cylindrical area with a width of at least 90 mm.

1. Open the clamp and bring the 1-arm bracket with the spherical rubber spacer into the desired position.
2. Tighten the clamp screw slightly so that you can still move the 1-arm bracket.
3. Adjust the tilt of the control computer holder by loosening and tightening the tilt adjustment screw.
 - Preferably set the inclination without the control computer.

In the connection between the 1-arm bracket and the adapter shell there is a tothing that makes it possible to align the adapter shell only in predefined positions.

 - Before tightening the tilt adjustment screw, make sure that the teeth mesh properly.
 - In addition, observe the torque indicated on the 1-arm bracket.
4. Place the 1-arm bracket in the final position and tighten the clamp screw.
 - Here too, observe the torque indicated on the 1-arm bracket.

The spherical spacer rubber makes it possible to move the 1-arm holder in all directions.

11.4 Control units

11.4.1 LED Remote

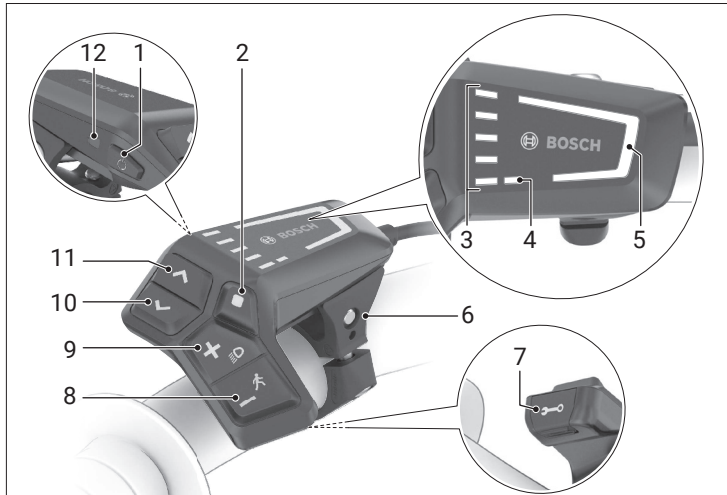







Fig.: 18 LED Remote control unit

- | | |
|--|--|
| 1 On/Off button  | 8 Decrease assistance  / walk assistance button |
| 2 Selection button  | 9 Increase assistance  / bike light button |
| 3 LEDs for charge status display | 10 Decrease brightness / Scroll back button  |
| 4 ABS LED (optional) | 11 Increase brightness / Scroll button  |
| 5 Assistance level LED | 12 Ambient light sensor |
| 6 Holder | |
| 7 Diagnostic connection (for maintenance purposes only) | |

11.4.2 Mini Remote

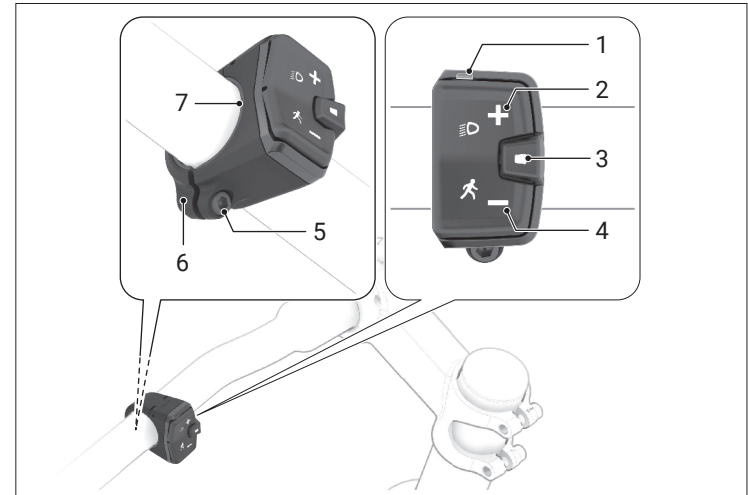





Fig.: 19 Mini Remote control unit

- | | |
|--|-----------------|
| 1 LED indicator light | 5 Fixing screw |
| 2 Increase assistance  / bike light button | 6 Holder |
| 3 Selection button  | 7 Rubber insert |
| 4 Decrease assistance  / walk assistance button | |

11.4.3 System Controller

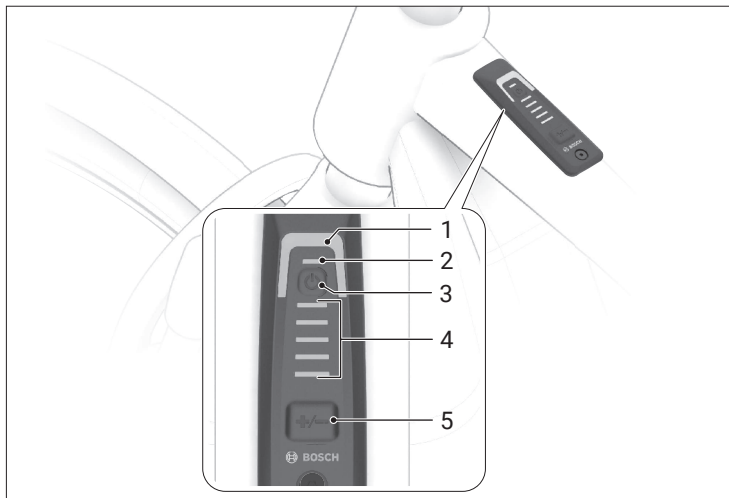

Fig.: 20 System Controller control unit

- | | |
|---|---|
| 1 Assistance level LED | 3 On/Off button  |
| 2 ABS LED (optional) / ambient light sensor | 4 LEDs for charge status display |
| | 5 Mode button  |

11.4.4 Proper use

The LED Remote, Mini Remote and System Controller control units are designed for controlling a Bosch eBike system and a control computer.

In order to be able to use the control units to their full extent, a compatible smartphone with the **eBike Flow** app (available from the Apple App Store or the Google Play Store) is required.

11.4.5 Requirements

The e-bike system can only be activated if the following conditions are met:

- An adequately charged battery has been inserted.
- The speed sensor is properly connected.

11.4.6 Power supply of the control unit

If a sufficiently charged e-bike battery is inserted into the e-bike and the e-bike system is switched on, the control unit battery is supplied with energy and charged by the e-bike battery.

LED Remote control unit only:

If the control unit battery should ever have a very low charge level, you can charge the internal battery with a power bank or another suitable power source via the diagnostic port using a USB Type-C® cable (charging voltage 5 V; charging current max. 600 mA). Always close the diagnostic port flap to prevent dust and moisture from entering.

Mini Remote control unit only:

The control unit is supplied with power by a CR1620 button battery. When the battery level is low, the orange LED indicator light flashes.

Changing the batteries:

1. Unscrew the control unit from the handlebars.
2. Remove the rubber insert which also functions as the battery holder.
3. Remove the used battery and replace with a new CR1620 battery. Ensure correct polarity when inserting the battery.
4. Push the battery and the rubber insert into the operating unit. If the battery is seated correctly, the green LED indicator light will flash for 10 s.
5. Then secure the operating unit back onto the handlebars.

 The connection to the System Controller is not interrupted when the battery is replaced. You can obtain the batteries recommended by Bosch from your bicycle dealer.

11.4.7 Switching the e-bike system on/off

LED Remote and System Controller control unit

Switching on

- To switch on the e-bike system, briefly press the On/Off button . After all LEDs light up briefly, you will see the charge level with the charge indicator and the set assistance level with the indicator in colour. The e-bike is ready to ride. The brightness of the display is controlled by the ambient light sensor. Therefore, do not cover the ambient light sensor.

The drive is activated as soon as you start pedalling (except in the OFF assistance level). The motor power depends on the set assistance level. As soon as you stop pedalling or as soon as you reach a speed of 25 km/h in normal operation, assistance from the e-bike drive will be deactivated.

The drive will automatically reactivate as soon as you continue pedalling and the speed is under 25 km/h.

Switching off

- To switch off the e-bike system, briefly press the On/Off button  (< 3 seconds). The battery charge indicator and the assistance level LED go out.

If no power is called up from the e-bike drive for about 10 minutes (e.g. because the e-bike is stationary) and no button is pressed on the control computer or control unit of the e-bike, the e-bike system switches off automatically.

11.4.8 Charge indicator

LED Remote and System Controller control unit

The charge indicator displays the charge level of the e-bike battery. The charge level of the e-bike battery can also be read from the LEDs on the battery itself.

In the display, each ice blue bar corresponds to 20% capacity and each white bar corresponds to 10% capacity.

The top bar shows the maximum capacity.



Example: Four ice-blue bars and one white bar are displayed. The charge level is between 81% and 90%.

When the capacity is low, the lower two indicators change colour:



| Bar | Capacitance |
|------------------|-------------------|
| 2 × orange | 30% ... 21% |
| 1 × orange | 20% ... 11% |
| 1 × red | 10% ... Reserve |
| 1 × red flashing | Reserve ... empty |

If the e-bike battery is being charged, the top bar of the charge indicator flashes.



11.4.9 Setting the assistance level

You can adjust how much the e-bike drive assists you while pedalling on the control unit with the buttons and  or the  button.

LED Remote and Mini Remote control unit:

- Press the  button to increase the assistance.
- Press the  button to decrease the assistance.

System Controller control unit:

- Press the  button to increase the assistance.
- Press the  button for more than 1 s to increase the assistance.

The assistance level can be changed at any time, even while riding, and is displayed in colour.

| Level | Notes |
|----------------|--|
| OFF | The motor assistance is deactivated, and the e-bike can be propelled by pedalling like a normal bike. |
| ECO | Effective assistance with maximum efficiency for maximum range |
| TOUR | Uniform assistance for long-distance trips |
| TOUR+ | Dynamic assistance for natural, sporty cycling |
| eMTB/ SPORT | Optimum support in any terrain, sporty start-up, improved dynamics, maximum performance |
| TURBO | Maximum assistance, supporting the highest pedalling frequency, for sportive riding |
| AUTO | The assistance adjusts dynamically to the riding situation. |
| RACE | Maximum support on the eMTB racetrack; very direct response and maximum "Extended Boost" for the best possible performance in competitive situations |
| CARGO | Steady, powerful assistance so as to be able to transport heavy weights |

The designations and design of the assistance levels can be preconfigured by the manufacturer and selected by the specialist dealer.



11.4.10 Interaction of the e-bike system with the shifting system

Even with an e-bike drive, you should use the shifting system as you would on a normal bike.

Regardless of the type of shifting system, it is advisable to briefly reduce the pedal pressure while shifting gears. This facilitates the shifting process and reduces drive train wear.

By choosing the right gear, you can increase speed and range with the same amount of power.

11.4.11 Switching the bicycle lights on/off

1. Check the correct function of your bicycle lights before each ride.
2. To switch on the bicycle lights, press the  button for more than 1 second.
3. With the  and  buttons, control the brightness of the LEDs on the control unit.

11.4.12 Shutting the walk assistance on/off



CAUTION

Risk of injury!

If the walk assistance function is used incorrectly, your limbs could get caught in rotating parts.

- Only use the walk assistance function when pushing the e-bike.
- Only use the walk assistance on level and solid ground.
- Only use the walk assistance function when both wheels of the e-bike are in contact with the ground.

Walk assistance helps you push the e-bike. In this function, the speed depends on the selected gear and may reach up to 6 km/h. The lower the gear, the lower the speed of the walk assistance function (at full output).



To start the walk assistance function, press the  button for more than 1 second and keep the  button pressed.

- The charge indicator goes out and a white running light in the direction of travel indicates readiness.

To activate the walk assistance function, one of the following actions must take place within the next 10 seconds:



- Push the e-bike forwards.
- Push the e-bike backwards.
- Perform a sideways swinging motion with the e-wheel.

After activation, the drive unit starts to push and the continuous white bars change colour to ice blue.

When you release the  button, the walk assistance function stops. Within 10 seconds, you can reactivate the walk assistance function by pressing the  button.

If you do not reactivate the walk assistance function within 10 seconds, it switches off automatically.

The walk assistance function is always terminated when:

- The rear wheel locks.
- Thresholds cannot be crossed.
- A part of the body blocks the bicycle crank.
- An obstacle keeps the crank turning.
- You start to pedal.
- The  button or the On/Off button  is pressed.

The operation of the walk assistance function is subject to country-specific regulations and may therefore differ from the above description or be deactivated.

11.4.13 ABS – Anti-lock braking system (optional)

If the bike is equipped with the Bosch eBike ABS, the ABS LED lights up when the e-bike system is started.

When the e-bike reaches a speed of 6 km/h, the ABS LED goes out.



In the event of a fault, the ABS LED lights up together with the orange flashing assistance level LED. You can acknowledge the error with the  selection button, and the flashing assistance level LED goes out. The ABS LED remains lit to indicate that the ABS is not operating.

- Details on ABS and how it works can be found in the section “6.5 Driving with ABS” on page 18.

11.4.14 Establish a smartphone connection

To use the following e-bike functions, a smartphone with the **eBike Flow** app is required.

The connection to the app is established via a Bluetooth® connection.

1. Switch on the e-bike system and do not ride the e-bike.
2. Start Bluetooth® pairing by pressing the On/Off button and keeping it pressed (> 3 s) 
 - Release the On/Off button  as soon as the top bar of the charge indicator shows the pairing process by flashing blue.
3. Confirm the connection request in the app.

11.4.15 Activity tracking

To record activities, registration or login to the **eBike Flow** app is required.

To record activities, you must agree to the storage of location data in the app. Only then can your activities be recorded in the app. You must be logged in as a user to record location data.

11.4.16 Lock function

The lock function can be set up and configured via the **eBike Flow** app. A digital key is stored on the smartphone, which is required to start the e-bike system.

After switching on the lock function, the e-bike can only be put into operation if:

- The configured smartphone is switched on.
- The smartphone has sufficient battery charge and the smartphone is in the immediate vicinity of the control unit.

Otherwise, the motor support remains off.

If the key is not verified immediately, the search for the key is indicated by white flashing of the battery charge indicator and the assistance level LED. If the key is found, the charge level and the last assistance level set are displayed after the white flashing light extinguishes.

If the key cannot be found on the smartphone, the e-bike system switches off. The indicators on the control unit go out.

Since the smartphone only serves as a contactless key when switched on, the e-bike battery and control computer can still be used on another, unlocked e-bike.

11.4.17 Software updates

Software updates are transferred in the background from the app to the control unit as soon as it is connected to the app. During the update, a green flashing of the charge indicator shows the progress. The system is then restarted. The software updates are controlled by the **eBike Flow** app.

11.5 Kiox 300 control computer

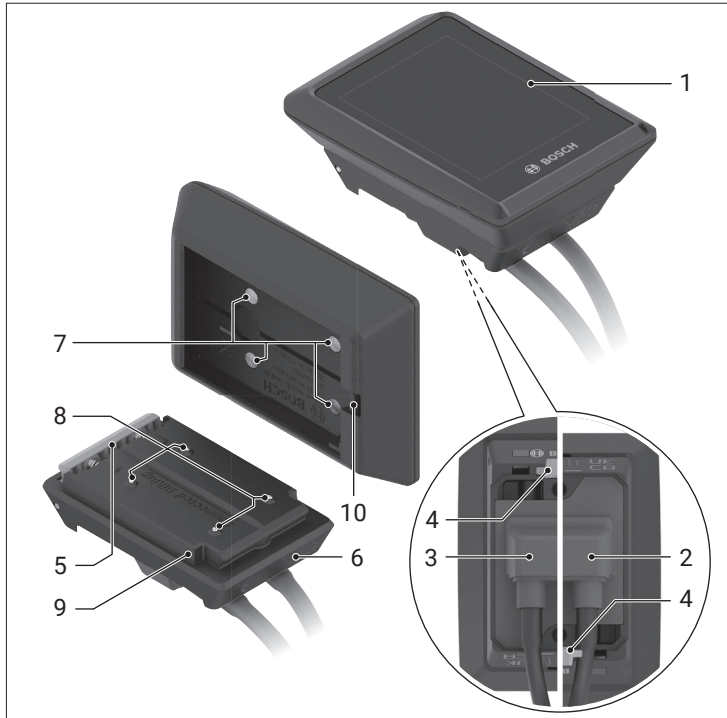

Fig.: 21 Kiox 300 control computer

- | | |
|-------------------------|----------------------------|
| 1 Display | 6 Adapter tray |
| 2 Cable outlet in front | 7 Display contacts |
| 3 Cable outlet rear | 8 Holder contacts |
| 4 Fuse plate | 9 Control computer holder |
| 5 Snap-in hook | 10 Bar for retaining strap |

11.5.1 Proper use

The Kiox 300 control computer is designed to display riding data.

In order to be able to use the Kiox 300 control computer to its full extent, a compatible smartphone with the **eBike Flow** app (available in the Apple App Store or the Google Play Store) is required.

11.5.2 Inserting and removing the control computer

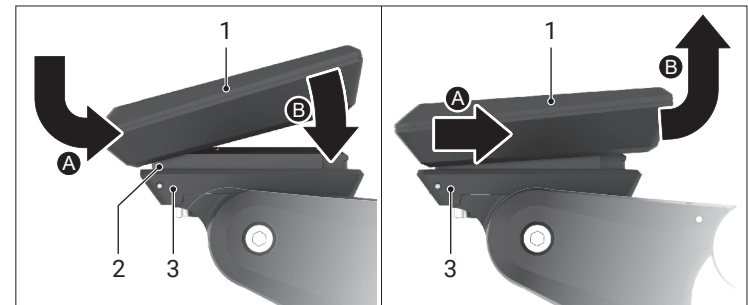

Fig.: 22 Mounting the Kiox 300 control computer

- | | |
|--------------------|---------|
| 1 Control computer | 3 Mount |
| 2 Snap-in hook | |

Insertion

- Place the control computer on the front edge of the holder in the direction of travel on the snap-in hook and press the rear side of the control computer onto the holder.

Removal

- Pull the control computer towards you until you can lift it off.

i A retaining strap can be attached to the bar.

11.5.3 Inserting the securing plate

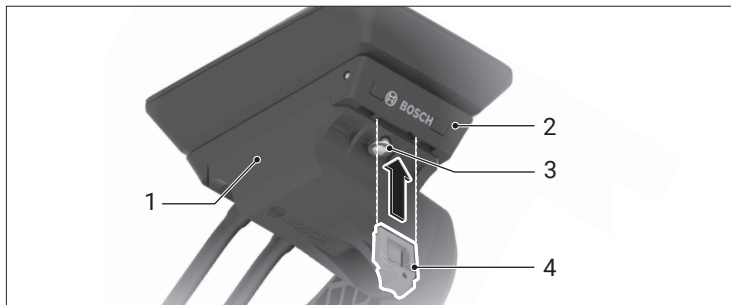

Fig.: 23 Inserting the securing plate

- 1 Adapter tray
- 2 Mount
- 3 Fixing screw
- 4 Fuse plate

- Push the securing plate into the adapter shell from below until the securing plate audibly engages.
From this point on, you can no longer lift the control computer off the mount without removing the mount from the adapter shell by loosening both fastening screws.

i The securing plate is not an anti-theft device.

11.5.4 Operation

The operation of the control computer and the control of the displays are carried out using a control unit.

The meaning of the buttons on the control unit can be found in the overview.

The selection button has two functions depending on how long it is pressed.

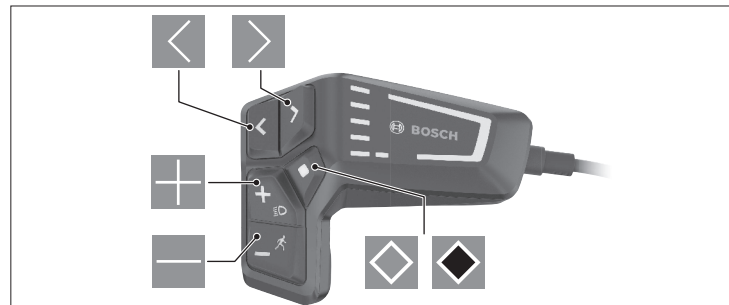

Fig.: 24 Operation of the Kiox 300 control computer

| | | |
|--|------------------|---|
| | Arrow key left | Scroll left |
| | Arrow key right | Scroll right |
| | Plus key | Scroll up |
| | Minus key | Scroll down |
| | Selection button | Switch to the second screen level (brief press) |
| | Selection button | Open screen-related options (long press > 1 s), e.g. open the Reset Trip or SETTINGS menu |

11.5.5 Start screen

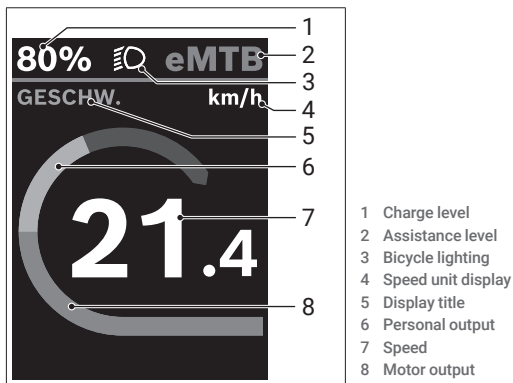





Fig.: 25 Kiox 300 start screen

If you did not select another screen before the last switch-off, this screen is displayed. Indicators 1 to 3 form the status bar and are displayed on each screen.

From this screen, you can switch to the status screen with the  arrow button or reach other screens with the  arrow button. These screens show you statistical data, the battery range and average values.

From each of these screens you can access a second level of data with the  selection button.

If you are on a screen other than the start screen when you switch off, the last screen displayed is shown when you switch on again.

By pressing and holding the  selection button, you can reset the statistical data of your trip or excursion (not in the Settings screen).

11.5.6 Status screen

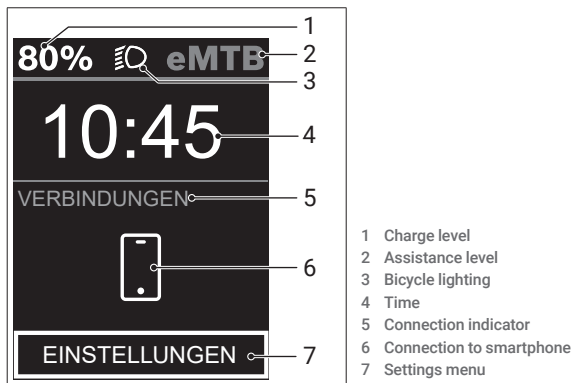



Fig.: 26 Kiox 300 status screen

From the start screen, you can reach the status screen by pressing the  arrow button.

From this screen, you can access the Settings menu by pressing the  selection button.

 The **SETTINGS** menu cannot be accessed while riding.

The **SETTINGS** menu contains the following menu items:

| My eBike | |
|-------------------------------|--|
| Reset | Reset value for range. |
| Reset Auto Trip | Settings for automatic reset. |
| Wheel Circumference | Adjust the value of the wheel circumference or reset to default. |
| Components | Display of the components used with version numbers. |
| System | |
| Language | Select preferred display language. |
| Units | Select preferred measurement system (metric/imperial). |
| Time | Set the time |
| Time Format | Select time format. |
| Brightness | Adjust the brightness of the display. |
| Resetting the settings | Reset all system settings to the default values. |
| Information | Information on contacts (Contact) and certificates (Certificates). |

Exit the Settings menu by pressing and holding the selection button.

Use the arrow button to reach the start screen.

11.6 Intuvia 100 control computer



Fig.: 27 Intuvia 100 control computer

- | | |
|---------------------------------|-----------------|
| 1 Control computer | 6 Reset button |
| 2 Bluetooth [®] button | 7 Locking screw |
| 3 Battery compartment | 8 Holder |
| 4 Locking screw holder | 9 Cradle |
| 5 Control computer contact | |

11.6.1 Proper use

The Intuvia 100 control computer is designed to display riding data.

In order to be able to use the Intuvia 100 control computer to its full extent, a compatible smartphone with the **eBike Flow** app (available in the Apple App Store or the Google Play Store) is required.

11.6.2 Inserting and removing the control computer

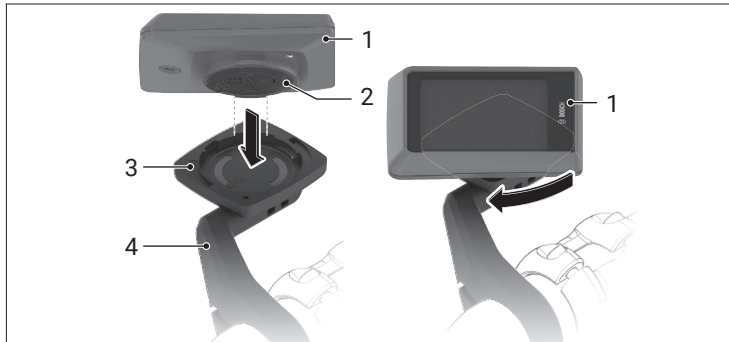

Fig.: 28 Mounting the Intuvia 100 control computer

- | | |
|-----------------------|----------|
| 1 Control computer | 3 Cradle |
| 2 Battery compartment | 4 Holder |

Insertion

1. Insert the control computer with the lugs of the battery compartment into the holder cradle and press the control computer gently down.
2. Turn the control computer clockwise until it engages.

Removal

1. Turn the control computer anticlockwise.
2. Remove the control computer from the holder cradle.

Remove the control computer when you park the e-bike.

11.6.3 Inserting the locking screw

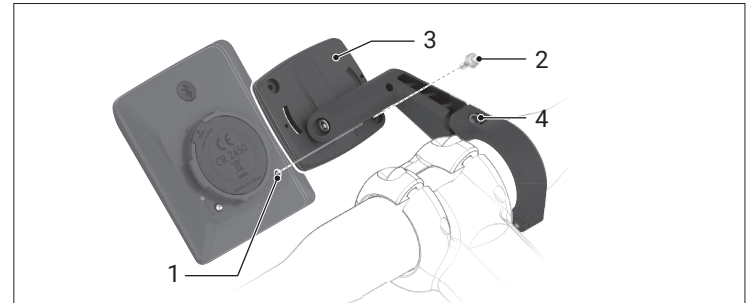



Fig.: 29 Inserting the locking screw

- | | |
|------------------------|-----------------------|
| 1 Locking screw holder | 3 Cradle |
| 2 Locking screw | 4 Fixing screw holder |

1. Loosen the fixing screw in the holder.
2. Turn the holder until the bottom side of the control computer is accessible.
3. Insert the locking screw and bolt it with the control computer.
4. Align the holder correctly with the control computer and tighten the fixing screw again.

 The locking screw is not designed to prevent theft.

11.6.4 Changing the batteries

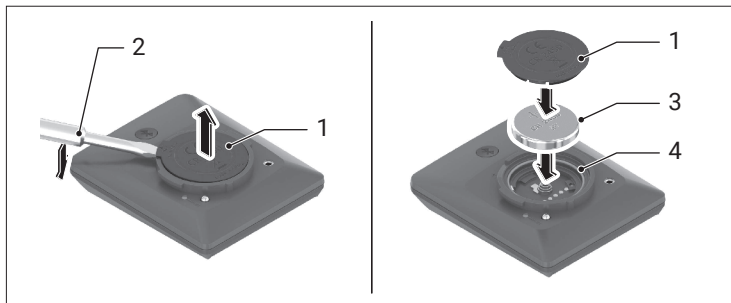

Fig.: 30 Inserting the locking screw

- 1 Battery compartment cover
- 2 Slotted screwdriver
- 3 Battery (CR2450 button battery)
- 4 Rubber seal

The control computer is powered by a CR2450 button battery. When the battery is nearly drained, a corresponding message will be shown on the display.

Changing the batteries:

1. Remove the control computer from the holder cradle.
2. Carefully open the battery compartment cover using a slotted screwdriver.
3. Remove the used battery and replace with a new CR2450 battery.
When inserting the battery, ensure correct polarity and the correct position of the rubber seal.
4. Close the battery compartment.
5. Then place the control computer back in the holder cradle.

You can obtain the batteries recommended by Bosch from your bicycle dealer.

11.6.5 Operation

The operation of the control computer and the control of the displays are carried out using one of the control units shown.

The meaning of the buttons on the control unit can be found in the overview.

The selection button has two functions depending on how long it is pressed.



Fig.: 31 Operation of the Intuvia 100 control computer (LED Remote and Mini Remote)

| | | |
|--|------------------|---------------------------------------|
| | Arrow key left | scroll to the left (LED Remote only) |
| | Arrow key right | scroll to the right (LED Remote only) |
| | Plus key | increase assistance level |
| | Minus key | decrease assistance level |
| | Selection button | (press briefly) |
| | Selection button | (press and hold > 1 s) |

11.6.6 Display indicator

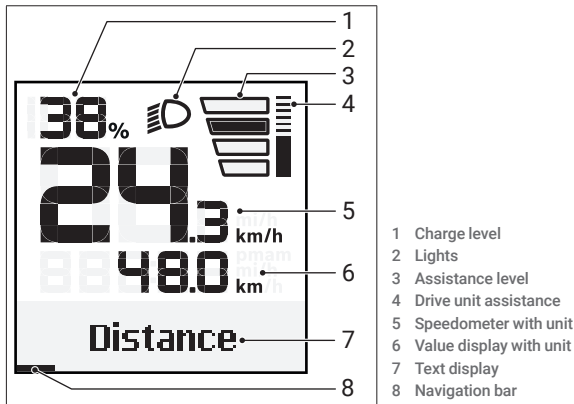

Fig.: 32 Intuvia 100 display indicator

- 1 Charge level
- 2 Lights
- 3 Assistance level
- 4 Drive unit assistance
- 5 Speedometer with unit
- 6 Value display with unit
- 7 Text display
- 8 Navigation bar

11.6.7 Speed and distance indicators

Change in the indicator function

LED Remote:

- Press the or button repeatedly until the desired function appears.

Mini Remote:

- Press the selection button repeatedly until the desired function appears.

Certain settings cannot be made on the control computer but only in the eBike Flow app.

The current speed is always shown on the speedometer.

The following functions are available in the function display – combination of text display and value display:

| | |
|-----------------------|--|
| Distance | distance travelled since the last reset |
| Cycling time | cycling time since the last reset |
| Time | current time |
| Range | estimated range of the available battery charge (in constant conditions such as assistance level, route profile, etc.) |
| Avg. speed | average speed achieved since the last reset |
| Max. speed | maximum speed achieved since the last reset |
| Total distance | total distance travelled with the e-bike (cannot be reset) |

The control computer automatically displays a gear change recommendation when riding the eBike. The display of the gear change recommendation is superimposed over the text display of the control computer, and can be deactivated manually via the basic settings.



11.6.8 Displaying and adjusting the basic settings

Displaying the basic settings menu

- Press the  selection button repeatedly until **Settings** is displayed in the text display.

Change basic settings

LED Remote:

- Press the  or  button repeatedly until the desired basic setting appears.

Mini Remote:

- Push the  selection button repeatedly until the desired basic setting appears.

Changing the basic settings

LED Remote:

- Briefly press the  selection button to scroll down until the required value is displayed.

Mini Remote:

- Press the  selection button for more than one second to scroll down until the required value is displayed.

Pressing and holding the relevant button switches automatically to the next value in the basic settings.

Leaving the basic settings menu

You leave the basic settings menu automatically if you are inactive for 60 s or start riding the eBike, or by using the **Back** function.

 The **Settings** menu cannot be accessed while riding.

You can select the following basic settings:

| | |
|-------------------------------|--|
| Language | You can select your preferred system language here |
| Units | You can display the speed and distance in either kilometres or miles |
| Time | You can set the time here. |
| Time Format | You can display the time in 12-hour or 24-hour format |
| Shift recommendation | You can choose whether or not to have a prompt displayed when it is recommended that you change gears. |
| Backlight | You can set the duration of the background lighting here |
| Brightness | The brightness can be adjusted in steps of 5% from 5–100%. |
| Resetting the settings | Here you can reset the settings by pressing and holding the  selection button |
| Certificate | |
| Back | Leaving the settings menu |

11.7 Drive unit

⚠ WARNING

Risk of interference with medical equipment!

Magnets can impair the function of implants or other medical devices such as pacemakers, defibrillators or insulin pumps.

- Keep magnets away from implants or other medical devices and make people wearing implants or medical devices aware of the danger.

NOTICE

Risk of damage!

Risk of irreversible loss of data and damage due to the action of the magnets.

- Keep magnets away from magnetic data carriers and magnetically sensitive devices.
- Avoid magnetic fields in the vicinity of the drive unit (e.g. magnetic clipless pedals, magnetic pedalling frequency sensors, etc.) so as not to interfere with the function of the drive unit.

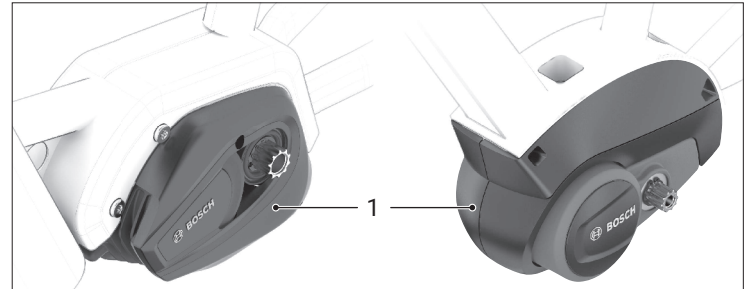

Fig.: 33 Drive unit overview

1 Drive unit

The e-bike drive supports you while you pedal. The drive only engages when you pedal. The motor output is always dependant on the power exerted while pedalling (See "6.2 Functionality" on page 16).

An exception applies to the walk assistance function, in which the e-bike can be pushed at low speed without pedalling (See "11.4.12 Shutting the walk assistance on/off" on page 39).

11.8 Speed sensor

WARNING

Risk of interference with medical equipment!

Magnets can impair the function of implants or other medical devices such as pacemakers, defibrillators or insulin pumps.

- Keep magnets away from implants or other medical devices and make people wearing implants or medical devices aware of the danger.
- To avoid adverse effects, do not hold magnets directly in front of the chest. Keep them at a minimum distance of 30 cm from the chest.

CAUTION

Risk of injury!

There is a risk of injury if your fingers or hand gets caught between the rim magnet and objects attracted by it. Injuries to the skin (e.g. if metal chips are attracted), crushing, bruising or fractures can result.

- Take care and wear appropriate protective clothing to avoid injury.

NOTICE

Risk of damage!

Risk of irreversible loss of data and damage due to the action of the magnets.

- Keep magnets away from magnetic data carriers and magnetically sensitive devices.

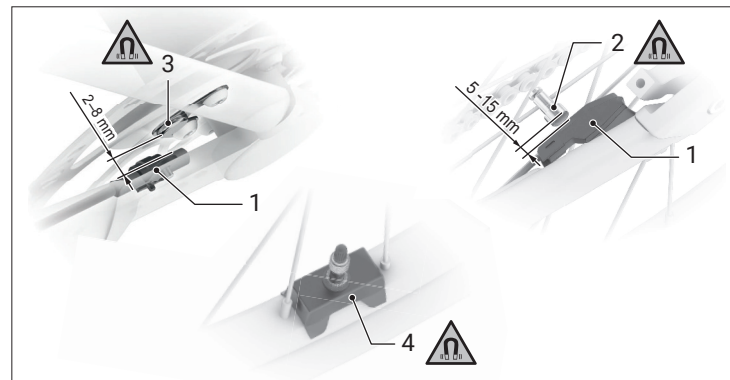

Fig.: 34 Checking the speed sensor (shape and mounting position may differ)

- | | |
|----------------|---------------------|
| 1 Speed sensor | 3 CenterLock magnet |
| 2 Spoke magnet | 4 Rim magnet |

11.8.1 Speed sensor (slim)

The speed sensor and the associated CenterLock magnet or spoke magnet are factory-mounted so that the magnet moves past the speed sensor at a distance of at least 2 mm and at most 15 mm during one revolution of the wheel.

In case of constructive changes, the correct distance between the magnet and the speed sensor must be maintained.

- When installing or removing the rear wheel, take care not to damage the speed sensor or sensor bracket.
- When changing the wheel, ensure that the sensor cables are laid without tension or kinks.

The CenterLock magnet can only be removed and reinserted up to 5 times.

11.8.2 Rim magnet

When a rim magnet is installed, no separate speed sensor is required to detect a wheel rotation. The speed sensor is integrated in the drive unit. The drive unit itself detects when the magnet is in its vicinity and calculates the speed and all other necessary data from the frequency of the emergence of the magnetic field.

12 Care

WARNING

Risk of electric shock and short circuit!

When performing care, maintenance and repairs, there is a risk associated with the electrical current.

- Check whether the mains plug of the charger has been pulled out of the socket.
- Remove the battery.
- Do not clean the components with running water or other liquids.
- Do not use a high-pressure cleaner or water jet.

CAUTION

Risk of injury!

The e-bike may respond in a manner other than you expect if operated incorrectly.

- Read the section *"11 Operation"* on page 26 completely before switching on for the first time.

Regular care will ensure that your e-bike stays safe and reliable.

- Wipe the e-bike components clean with a slightly damp cloth.
- Use a mild cleaner.
- Check to make sure that all electrical lines, connections and contacts are not damaged and are clean (visual inspection).
- Have damaged or corroded parts replaced by your specialist dealer.
- Prevent moisture or dirt from contaminating the contacts.

12.1 Notes on the battery lock key

- Take note of the key number(s) imprinted on the key.
- If you lose the key, contact your specialist dealer for a replacement key.

13 Disposal

- Read the explanation of the symbols printed or embossed on the packaging, battery and charger (See "5.1 Symbols on the products" on page 14).
- Contact your specialist dealer or the appropriate authorities for information on disposal.

13.1 Disposing of the e-bike and charger

(Applicable in the European Union and other European countries with separate collection systems for recyclable materials)

Electronic waste equipment must not be disposed of in household waste.

The e-bike and charger are electrical appliances. Consumers are legally obliged to hand in old electrical appliances separately from household waste, e.g. at a recycling centre or a collection point in their municipality/district, for disposal or for the purpose of reuse. In addition, there is the possibility to hand in old electrical appliances free of charge at the dealer. This will guarantee that waste equipment can be correctly recycled and any negative impact on the environment can be avoided.

Before disposal, all batteries and batteries as well as all operating parts containing batteries or batteries must be removed from the e-bike. Lamps are also to be removed, provided they can be removed non-destructively. The deletion of personal data stored on the waste equipment to be disposed of is the responsibility of the consumer.



Electrical appliances that must be returned or recycled as described are marked with the symbol shown here.

Conformity with RoHS Directive: The product you have purchased complies with the EU RoHS Directive (2011/ 65/ EC). It does not contain any harmful and prohibited materials specified in the Directive.

13.2 Disposing of rechargeable batteries and batteries

Rechargeable batteries and batteries must not be disposed of in the household waste.

Rechargeable batteries that supply the motor with energy and permanently installed rechargeable display batteries or display batteries are usually lithium-ion rechargeable batteries or lithium-ion batteries that must be disposed of as special waste or taken to a separate used battery collection. Consumers are legally obliged to return rechargeable batteries and batteries to a suitable place, as rechargeable batteries and batteries sometimes contain toxic substances. The separate collection and recycling of spent batteries and accumulators is intended to ensure proper disposal or recycling in order to avoid harmful (health) effects on people and the environment.

In order to avoid battery waste, every consumer is generally required to use long-life and/or batteries or accumulators and to handle batteries and accumulators and the devices operated with them with care. Before batteries and accumulators are disposed of, it should always be checked whether the respective product can be reused by repair or reconditioning.

Due to the product-specific hazards posed by lithium-ion rechargeable batteries and lithium-ion batteries, special care must be taken when using lithium-ion rechargeable batteries and lithium-ion batteries. When exposed to heat, for example, there is an increased risk of explosion and fire.

The return of batteries and accumulators is free of charge and can be done at the dealer or at a suitable collection point of the city or municipality. Information on collection points is provided by city and local governments.



Batteries and batteries that must be disposed of or recycled as described are marked with the symbol shown here.

For batteries/batteries containing mercury (Hg), cadmium (Cd) or lead (Pb), the corresponding chemical symbol is also shown below the symbol.

13.3 Disposing of the packaging

Sort the packaging before you dispose of it. Dispose of cardboard and carton as waste paper and foils via the recyclable material collection service.

14 Error messages

14.1 LED Remote control unit

The control unit indicates whether critical faults or less critical faults occur in the e-wheel system.

The error messages generated by the e-bike system can be read out via the **eBike Flow** app or by your specialist dealer. Via a link in the **eBike Flow** app, you can be shown information about the error and support for rectifying the error.

14.1.1 Fewer critical errors

Fewer critical errors are indicated by orange flashing of the assistance level LED. Pressing the selection button  confirms the error and the assistance level LED again constantly shows the colour of the set assistance level.

You can correct the errors yourself with the help of the following table. Otherwise, please consult your specialist dealer.

| Error number | Troubleshooting |
|--------------|--|
| 0x523005 | <p>The error numbers given indicate that there are impairments in the detection of the magnetic field by the sensors. Check if you have lost the magnet while riding.</p> <p>If you use a spoke magnet or CenterLock magnet, check that the sensor and magnet are mounted properly. Also make sure that the cable to the sensor is not damaged.</p> <p>If you use a rim magnet, make sure that you do not have any interference magnetic fields near the drive unit.</p> |
| 0x514001 | |
| 0x514002 | |
| 0x514003 | |
| 0x514006 | |

14.1.2 Critical errors

Critical faults are indicated by red flashing of the assistance level LED and the charge indicator.

- In the event of a critical fault, consult a specialist dealer as soon as possible.
- Do not connect a charger to the system!

14.2 Battery

The Bosch e-bike battery must not be opened, not even for repair purposes. There is a risk that the Bosch e-bike battery may catch fire, e.g. due to a short circuit. This danger also exists at a later time if you continue to use a Bosch e-bike battery once it has been opened.

- Therefore, in the event of a fault, do not have the Bosch e-bike battery repaired, but have it replaced by your specialist dealer with an original Bosch e-bike battery.

14.3 Charger

| Fault | Cause | Remedy |
|---|------------------------------------|---|
| Two LEDs on the battery flash. | Battery defective | Contact an authorised dealer. |
| Three LEDs on the battery flash. | Battery too warm or too cold | Disconnect the battery from the charger until the charging temperature range is reached. Only connect the battery to the charger again once it has reached the permissible charging temperature. |
| No LED flashes (depending on the charging status of the e-bike battery, one or more LEDs light up permanently). | The charger is not charging. | Contact an authorised dealer. |
| No charging possible (no display on the battery) | Plug not inserted correctly | Check all plug connections. |
| | Contacts on the battery dirty | Carefully clean the contacts on the battery. |
| | Socket, cable or charger defective | Check mains voltage, have charger checked by specialist dealer. |
| | Battery defective | Contact an authorised dealer. |

15 Technical data

15.1 Control computer

| Kiox 300 | |
|------------------------|---------------|
| Product code | BHU3600 |
| Operating temperature* | -5 ... +40°C |
| Storage temperature | +10 ... +40°C |
| Protection class IP54 | IP54 |
| Weight, approx. | 32 g |

*Outside this temperature range, the display may malfunction.

The licensing information for the product is available at the following Internet address:
<https://www.bosch-ebike.com/licences>.

| Intuvia 100 | |
|---------------------------|---------------|
| Product code | BHU3200 |
| Operating temperature* | -5 ... +40°C |
| Storage temperature | +10 ... +40°C |
| Battery (button battery) | 1× CR2450 |
| Protection class IP54 | IP54 |
| Weight, approx. | 63 g |
| Bluetooth® Low Energy 5.0 | |
| Frequency | 2400-2480 MHz |
| Transmitting power | 1 mW |

*Outside this temperature range, the display may malfunction.

The licensing information for the product is available at the following Internet address:
<https://www.bosch-ebike.com/licences>.

15.2 Control computer holder

| | |
|-----------------------|--|
| Product code | BDS3210 BDS3250 BDS3620 BDS3630 |
| Output voltage | 4.75 ... 5.4 V |
| Max. output current | 1.5 A |
| Operating temperature | -5 ... +40°C |
| Storage temperature | +10 ... +40°C |
| Protection class | IP54 |

15.3 Control unit

| Mini Remote | |
|-------------------------------|-----------------|
| Product code | BRC3300 |
| Operating temperature | -5 ... +40°C |
| Storage temperature | +10 ... +40°C |
| Battery (button battery) | 1× CR1620 |
| Protection class | IP54 |
| Dimensions (without mounting) | 40 x 39 x 22 mm |
| Weight | 16 g |
| Bluetooth® Low Energy 5.0 | |
| Frequency | 2400-2480 MHz |
| Transmitting power | ≤1 mW |

The licensing information for the product is available at the following Internet address:
<https://www.bosch-ebike.com/licences>.

| LED Remote | |
|---|----------------------------|
| Product code | BRC3600 |
| Max. charging current, USB port ¹⁾ | 600 mA |
| Charging voltage, USB port | 5 V |
| USB charging cable ³⁾ | USB type C ^{® 2)} |
| Charging temperature | 0 ... +45°C |
| Operating temperature | -5 ... +40°C |
| Storage temperature | +10 ... +40°C |
| Diagnostic interface | USB Type-C ^{® B)} |
| Lithium-ion battery internal | 3.7 V 75 mAh |
| Protection class | IP54 |
| Dimensions (without mounting) | 74 x 53 x 35 mm |
| Weight | 30 g |
| Bluetooth[®] Low Energy 5.0 | |
| Frequency | 2400-2480 MHz |
| Transmitting power | 1 mW |

| System Controller | |
|---|-----------------|
| Product code | BRC3100 |
| Operating temperature | -5 ... +40°C |
| Storage temperature | +10 ... +40°C |
| Protection class | IP54 |
| Dimensions (without mounting) | 88 x 28 x 27 mm |
| Weight | 35 g |
| Bluetooth[®] Low Energy 5.0 | |
| Frequency | 2400-2480 MHz |
| Transmitting power | ≤1 mW |

The licensing information for the product is available at the following Internet address:
<https://www.bosch-ebike.com/licences>.

¹⁾ Information about charging the LED Remote; external devices cannot be charged.

²⁾ USB type-C[®] and USB-C[®] are trademarks of the USB Implementers Forum.

³⁾ Not included in the delivery.

15.4 Bicycle lighting

NOTICE

Risk of damage!

Incorrectly inserted lamps can be destroyed.

- Only use Bosch e-bike system compatible lamps.
- Only use lamps with the same voltage.
- Contact your dealer if you are unsure.

| Bicycle lighting | |
|-----------------------------|--------|
| Voltage approx. | 12 V = |
| Maximum output, front light | 17.4 W |
| Maximum output, rear light | 0.6 W |

Energy supply not possible in all country-specific versions via the e-bike battery, depending on legal regulations.

15.5 Bosch eBike ABS

| BAS3311 | |
|-----------------------|----------------|
| Product code | BAS3311 |
| Operating temperature | -5° ... +40°C |
| Storage temperature | +10° ... +40°C |
| Protection class | IPx7 |
| Weight, approx. | 3.2 kg |

15.6 Drive unit

| Performance Line | |
|------------------------|----------------|
| Product code | BDU3360 |
| Rated continuous power | 250 W |
| Max. torque on drive | 75 Nm |
| Nominal voltage | 36 V = |
| Operating temperature | -5° ... +40°C |
| Storage temperature | +10° ... +40°C |
| Protection class | IP54 |
| Weight, approx. | 3.2 kg |

The Bosch e-bike system uses FreeRTOS (see <http://www.freertos.org>).

| Performance Line CX / Cargo / CX Race Edition / Speed | |
|---|---|
| Product code | BDU3740 / BDU3741 / BDU3760 / BDU3761 / BDU3780 / BDU3781 |
| Rated continuous power | 250 W |
| Max. torque on drive | 85 Nm |
| Nominal voltage | 36 V = |
| Operating temperature | -5° ... +40°C |
| Storage temperature | +10° ... +40°C |
| Protection class | IP54 |
| Weight, approx. | 3 kg |

The Bosch e-bike system uses FreeRTOS (see <http://www.freertos.org>).

15.7 Lithium ion rechargeable battery

| PowerTube 500 / PowerTube 625 / PowerTube 750 | | | |
|---|----------------|---------|---------|
| Product code | BBP3750 | BBP3760 | BBP3770 |
| Nominal voltage | 36 V = | | |
| Nominal capacitance | 13.4 Ah | 16.7 Ah | 20.1 Ah |
| Energy | 500 Wh | 625 Wh | 750 Wh |
| Operating temperature | -5° ... +40°C | | |
| Storage temperature | +10° ... +40°C | | |
| Permissible charging temperature range | 0° ... +40°C | | |
| Weight, approx. | 3.0 kg | 3.6 kg | 4.3 kg |
| Protection class | IP54 | | |

| PowerPack 545 / PowerPack 725 | | |
|--|----------------|---------|
| Product code | BBP3551 | BBP3570 |
| Nominal voltage | 36 V = | |
| Nominal capacitance | 14.4 Ah | 19.2 Ah |
| Energy | 545 Wh | 725 Wh |
| Operating temperature | -5° ... +40°C | |
| Storage temperature | +10° ... +40°C | |
| Permissible charging temperature range | 0° ... +40°C | |
| Weight, approx. | 3.0 kg | 4.0 kg |
| Protection class | IP54 | |

15.8 Charger

| 4A charger | |
|---------------------------|-----------------------|
| Product code | BPC3400 |
| Nominal voltage | 198 - 264 V~ |
| Frequency | 47 - 63 Hz |
| Battery charging voltage | 36 V = |
| Max. charging current | 4 A |
| Approx. charging time | 4.5 h / 5.4 h / 6.0 h |
| PowerTube 500 / 625 / 750 | |
| PowerTube 545 / 725 | 4.9 h / 6.0 h |
| Operating temperature | 0° ... +40°C |
| Storage temperature | +10° ... +40°C |
| Weight, approx. | 0.7 kg |
| Protection class | IP40 |

The specifications apply to a nominal voltage [U] of 230 V. These specifications may vary for different voltages and in country-specific versions.



HARTJE
TRADITION IN BEWEGUNG - SEIT 1895

Hermann Hartje KG
Deichstraße 120-122
27318 Hoya/Weser

Phone: +49(0)4251/811-0
Fax: +49(0)4251/811-159
info@hartje.de · www.hartje.de

EC DECLARATION OF CONFORMITY

according to EC directive 2006/42/EC on machinery (Annex II A)

Name and address of the manufacturer:

Hermann Hartje KG, Deichstr. 120 - 122, 27318 Hoya/Weser, Germany

This declaration relates exclusively to the machinery in the state in which it was placed on the market, and excludes components which are added and/or operations carried out subsequently by the final user. The declaration is no more valid, if the product is modified.

Herewith we declare, that the product described below:

E-Bike Q10 model:

EINS P-5, EINS P-E, EINS P-R, EINS + P-E

Modelyear 2023 + battery charger

is complying with all essential requirements of the Machinery Directive 2006/42/EC and Directive 2014/30/EU relating to electromagnetic compatibility.

The following technical standards were used:

DIN EN ISO 4210:2021-01 Cycles -- Safety requirements for bicycles
DIN EN 15194:2018-11(D) Electrically power assisted cycles (EPAC)

Hoya/Weser, August 2022

Management:
Dirk Zwick

17 Legal notice

Responsible for sales and marketing

Hermann Hartje KG

Deichstrasse 120–122

27318 Hoya/Weser (Germany)

Tel. +49 (0) 4251–8111-90

info@hartje.de

www.hartje.de

Text, content and layout

PlusDocu GmbH

Stralauer Platz 34

10243 Berlin (Germany)

info@plusdocu.com

www.plusdocu.com

The user manual is a supplemental user manual for your bicycle and meets the requirements and the domain of validity of the EN 15194 and EN 82079-1 standards.

© Duplication, reproduction and translation as well as any commercial exploitation, including excerpts, in printed or electronic form, is permissible only with prior written approval.

Version 2022_02_QIO_E-RAD_BOSCH_EN





Presented by

Sales:

Hermann Hartje KG

Tel: +49 (0)4251 811 500

info@hartje.de

www.hartje.de

Qio